

# final report

Project code: A.ENV.0101  
Prepared by: Trevor Bridle  
Bridle Consulting  
Date submitted: October 2010  
Date published: March 2011

PUBLISHED BY  
Meat & Livestock Australia Limited  
Locked Bag 991  
NORTH SYDNEY NSW 2059

## **Waste to energy: Alternative uses for paunch waste and DAF sludge**

### **Waste pyrolysis review**

Meat & Livestock Australia acknowledges the matching funds provided by the Australian Government to support the research and development detailed in this publication.

This publication is published by Meat & Livestock Australia Limited ABN 39 081 678 364 (MLA). Care is taken to ensure the accuracy of the information contained in this publication. However MLA cannot accept responsibility for the accuracy or completeness of the information or opinions contained in the publication. You should make your own enquiries before making decisions concerning your interests. Reproduction in whole or in part of this publication is prohibited without prior written consent of MLA.

### Abstract

Major research is underway to improve abattoir waste management practises, reduce disposal costs, minimise fossil fuel consumption and investigate the potential for abattoir's to produce their own renewable energy. One enabling technology that could achieve these goals is pyrolysis and this study involved a review of waste pyrolysis and it's potential to process abattoir wastes. This review has confirmed that the technology is used at commercial scale predominately in Europe and Japan but that there are no commercial facilities operating on abattoir solid wastes. Eight Australian pyrolysis vendors were identified and their processes were reviewed. Preliminary economic analysis reveals that pyrolysis of abattoir wastes could be commercially attractive and that this process could reduce the carbon footprint of abattoirs. It is recommended that pilot trialling of Australian Pyrolysis processes be conducted to confirm this finding.

### Executive summary

Major research is underway to improve abattoir waste management practises, reduce disposal costs, minimise fossil fuel consumption and investigate the potential for abattoir's to produce their own renewable energy. As part of this research MLA and AMPC have approved a research project entitled "Waste to Energy: Alternative uses for paunch waste and DAF sludge". Phase 1 of this project involves conducting a high level desktop review of waste pyrolysis systems and to ascertain whether pyrolysis has the potential to economically process paunch waste and DAF sludge to biochar and syngas to reduce the carbon footprint of meat processing facilities. The specific objectives of the study include:

- an overview of waste pyrolysis;
- identification and review of Australian waste pyrolysis providers and their processes;
- a site visit to Black is Green P/L in Mackay to review their pyrolysis system;
- develop order-of-magnitude economics for the pyrolysis of paunch waste and DAF sludge; and
- propose and develop a pyrolysis test programme based on the use of Australian pyrolysis system providers equipment.

Waste pyrolysis, also called carbonisation, is universally regarded as a process where waste is heated indirectly, in the absence of oxygen, to a temperature of between 350 and 500 °C. Under these conditions the waste decomposes and about 30 to 60% of the dry mass is volatilised to produce a crude syngas with the remaining solids converted to a char product. In essence, pyrolysis is the thermal destructive distillation of organic materials. The process is endothermic and requires about 1 to 1.5 GJ of thermal energy per tonne of dried waste processed. Unlike gasification, which involves some combustion of the feedstock, pyrolysis involves NO combustion and consequently the products contain all of the chemical energy that was present in the original waste material. Pyrolysis can be characterised as "Fast Pyrolysis" or "Slow Pyrolysis". Fast pyrolysis occurs in a matter of a few seconds or less and decomposes organics to mostly vapours, aerosols and some char. Fast pyrolysis maximises the production of syngas and liquid products. Slow pyrolysis requires a slow reaction time, typically hours or even days, at low temperatures (less than 500 °C) to maximise the yield of solid char. Fast pyrolysis is not the preferred process for non-homogeneous wastes such as abattoir wastes due to the need for finely ground and uniform quality feedstocks.

There are no commercial waste pyrolysis systems currently operating in Australia but there are systems operating in Europe, the US and Japan. The only waste pyrolysis system that has operated in Australia was the sewage sludge pyrolysis facility in Perth, WA. The facility was designed to process 25 dry tpd of sewage sludge and operated for about 2 years before being shut down by the client (Water Corporation of WA) due primarily to cost considerations. Thide Environnement of France has developed a slow pyrolysis process called EDDITh. This process is based on the use of rotary kiln reactors and there is one commercial facility operating in France and two in Japan, built by the Thide licensee, Hitachi Corporation. All of the facilities process predominately MSW with small amounts of industrial wastes and sewage sludge. Plant capacities vary from 70 to 200 dry tpd. WasteGen Ltd of the UK and their German technology provider Tech Trade GmbH has supplied many solid waste pyrolysis facilities that are based on the use of rotary kiln technology. Most of their plants are in Europe and range from 70 to 270 tpd in size, processing predominately MSW. The largest plant in Hamm, Germany produces 8.3 MW of electricity, via steam turbines. ZWT GmbH of Germany has supplied a commercial 6 tpd

## Waste to energy: Alternative uses for paunch waste and DAF sludge

---

pyrolysis facility that has been operating at a sewage treatment plant in the town of Mintraching, Germany since 2009.

Eight Australian companies who offer pyrolysis and gasification systems have been identified and these companies are listed below:

- AnthroTerra Pty Ltd of Somersby, NSW,
- Biochar-Energy Systems Pty Ltd of Bendigo, VIC,
- Black is Green Pty Ltd of Mackay, QLD,
- Chaotech Pty Ltd of Rocklea, QLD,
- Crucible Carbon Pty Ltd of Sydney, NSW,
- New Energy Corporation Pty Ltd of Perth, WA,
- Pacific Pyrolysis Pty Ltd of Somersby, NSW, and,
- Renewable Oil Corporation Pty Ltd of Surrey Hills, VIC.

As yet none of these companies have any commercial facilities operating but they have generated significant expertise in the processing of waste materials using large-scale pilot plants. Most vendors indicated that the feed material needs to have a moisture content of less than 20% prior to processing, implying that abattoir solid waste will require thermal drying prior to pyrolysis. Many of these vendors are in the initial stages of supplying commercial facilities.

Budget economics for 5 and 20 dry tpd gasification and pyrolysis plants processing a combined paunch waste and DAF sludge feedstock have been developed based primarily on process information and cost data provided by the vendors. It is noted that there was a paucity of waste characteristics data for use by the vendors for the process design of the pyrolysis or gasification systems. Costs for drying of the feedstock were developed by Bridle Consulting. This preliminary budget cost data indicates that for small plants of 5 dry tpd throughput the economics are at best marginal. The only option that looks potentially profitable is gasification with power generation and char to agriculture. All the other options incur costs ranging from \$53 to \$212 per dry tonne of feedstock. As is to be expected, the economics for larger 20 tpd facilities look far more attractive. Depending on the process used and the char end-use, credits of between \$24 and \$94 per dry tonne are possible. Whilst these economics are very preliminary in nature they do indicate that gasification or pyrolysis of paunch waste and DAF sludge, with power generation, can provide positive returns and carbon credits for larger plants.

Based on the outcomes of this study the following recommendations are made:

1. It is recommended that MLA embark on detailed paunch waste and DAF sludge characterisation study to provide the information necessary to better assess the potential of pyrolysis and gasification for the cost-effective processing of these waste streams.
2. To confirm the budget economics developed in this study it is recommended that pilot plant trialling of Australian pyrolysis and gasification technologies are undertaken.

## Contents

	Page
<b>1</b>	<b>Background ..... 7</b>
1.1	The Strategic Issue ..... 7
1.1.1	The way forward..... 7
<b>2</b>	<b>Project objectives ..... 7</b>
2.1	The broad objective ..... 7
2.1.1	Specific objectives for this project ..... 8
<b>3</b>	<b>Methodology..... 8</b>
3.1	Pyrolysis overview ..... 8
3.2	Review of Australian pyrolysis systems ..... 8
3.3	Site visit to Black is Green P/L in Mackay..... 8
3.4	Budget pyrolysis economics ..... 9
3.5	Develop a pyrolysis test programme..... 9
<b>4</b>	<b>Results and discussion..... 9</b>
4.1	Pyrolysis overview ..... 9
4.1.1	Fast or flash pyrolysis..... 10
4.1.2	Slow pyrolysis ..... 11
4.1.3	Pyrolysis reactor configurations ..... 12
4.1.4	Pyrolysis feedstock quality issues ..... 13
4.1.5	Commercial waste pyrolysis systems..... 13
4.1.6	Pyrolysis experience with abattoir solid wastes..... 19
<b>4.2</b>	<b>Review of Australian pyrolysis systems ..... 21</b>
4.2.1	AnthroTerra P/L process ..... 21
4.2.2	Biochar-Energy Systems P/L process ..... 22
4.2.3	Black is Green P/L process ..... 23
4.2.4	Chaotech P/L process ..... 26
4.2.5	Crucible Carbon P/L process ..... 26
4.2.6	New Energy Corporation P/L process ..... 28
4.2.7	Pacific Pyrolysis P/L process ..... 29
4.2.8	Renewable Oil Corporation P/L process ..... 31
4.2.9	ZWT GmbH process..... 31
<b>4.3</b>	<b>Site visit to Black is Green P/L in Mackay..... 34</b>
<b>4.4</b>	<b>Budget pyrolysis economics ..... 35</b>

4.4.1	Waste characteristics .....	36
4.4.2	Drying issues.....	36
4.4.3	Pyrolysis performance.....	37
4.4.4	Char value .....	37
4.4.5	Budget economics.....	37
4.5	<b>Recommended pyrolysis test programme.....</b>	<b>40</b>
<b>5</b>	<b>Success in achieving objectives.....</b>	<b>41</b>
<b>6</b>	<b>Impact on meat and livestock industry – Now and in five years time .....</b>	<b>41</b>
<b>7</b>	<b>Conclusions and recommendations.....</b>	<b>41</b>
7.1	Conclusions.....	41
7.2	Recommendations .....	42

# 1 Background

## 1.1 The Strategic Issue

The impacts of climate change on the red meat industry have been a focus of the R&D effort by both MLA and AMPC in the recent past. Some of the key areas of focus for this climate change research have been on improving abattoir waste management practises, reducing disposal costs, minimise fossil fuel consumption and investigate the potential for abattoir's to produce their own renewable energy. Currently, there is a broad variation across the industry in the management of abattoir waste solids. Generally, waste solids are processed through anaerobic/aerobic biological treatment processes in ponds and disposed of through spreading on surrounding agricultural land or sent to the local waste disposal facilities (landfills). There is currently little effort put into reusing the nutrients and energy that are contained within the solid waste streams produced by the red meat processing sector. Two of the solid waste streams that are of interest are paunch waste and DAF sludge. Many plants are currently paying to dispose of the paunch waste while a few can dispose of it at zero net cost, but it is uncertain whether they will be able to do the same in the future. Disposal of DAF sludge always incurs a cost.

### 1.1.1 The way forward

Some consideration has been given in the past to the use of paunch waste and sludge to feed boilers, typically mixed with other fuels but the results were not fully conclusive. It was however shown that these types of wastes can only be combusted in boilers in an energy positive manner if the moisture content is under 55%-60%. A number of alternative energy recovery options were investigated in a previous Plant Initiated Project conducted at the then Australia Meat Holdings plant at Dinmore. Pyrolysis was considered in a comparison of available technologies, but was not recommended for a number of plant specific reasons. Currently, there are a number of large scale pyrolysis plants that have been established around the world that use a variety of feedstocks to produce syngas and char. The major feedstocks used are municipal solid waste (MSW), green waste, timber milling wastes and sugar cane trash. There is currently no large scale, commercially sized pyrolysis plant using abattoir waste solids as a feedstock.

The Nippon Meat Packers abattoir at Mackay has been approached by a specific provider of pyrolysis technology with a view to conducting joint research into the potential of using abattoir waste solids in the pyrolysis process. From this initial contact, Nippon approached MLA/AMPC to broaden the scope of the project to become a more detailed investigation of the general benefits of pyrolysis of solid wastes to the red meat processing sector.

# 2 Project objectives

## 2.1 The broad objective

MLA and AMPC have approved a research project entitled "Waste to Energy: Alternative uses for paunch waste and DAF sludge". The broad objectives of this project are to:

- identify suitable waste-to-energy pyrolysis systems that could be used to process paunch waste and DAF sludge to generate biochar and syngas to be used to minimise the carbon footprint of meat processing facilities; and

- assess the potential for reduction of boiler fossil fuel consumption through replacement of these fuels with processed paunch waste and DAF sludge and thus reduce the carbon footprint of meat processing facilities.

### 2.1.1 Specific objectives for this project

Phase 1 of this MLA/AMPC project involves conducting a high level desktop review of waste pyrolysis systems and to ascertain whether pyrolysis has the potential to economically process paunch waste and DAF sludge to biochar and syngas to reduce the carbon footprint of meat processing facilities. The specific objectives of the study include:

- an overview of waste pyrolysis;
- identification and review of Australian waste pyrolysis providers and their processes;
- a site visit to Black is Green P/L in Mackay to review their pyrolysis system;
- develop order-of-magnitude economics for the pyrolysis of paunch waste and DAF sludge; and
- propose and develop a pyrolysis test programme based on the use of Australian pyrolysis system providers equipment.

## 3 Methodology

### 3.1 Pyrolysis overview

An overview of the basic principles of pyrolysis will be provided as well as a world-wide literature review of waste pyrolysis developments and progress over the last 30 years. This review will identify if any information on the pyrolysis of abattoir solid wastes has been generated and published. Systems that condense the syngas to produce oil as well as those that combust the syngas will be discussed.

### 3.2 Review of Australian pyrolysis systems

All public and private companies in Australia who offer waste pyrolysis systems will be contacted and their systems will be reviewed and assessed. This assessment will include a technical review of their process and equipment, a review of the status of their developmental programmes, a review of their waste processing experience, an assessment of the commercial status of their technology and a preliminary economic assessment of their system. MLA/AMPC have identified five Australian companies who offer waste pyrolysis systems and these companies will be included in the review as well as all other companies who publicly offer commercial or pilot plant waste pyrolysis systems.

### 3.3 Site visit to Black is Green P/L in Mackay

Black is Green P/L, a Mackay-based company has developed and patented a vertical rotary-hearth based pyrolysis system (BigChar) and has offered to test the system on abattoir solid wastes from Nippon Meat Packers. A site visit will be made to BigChar in Mackay to view their pyrolysis system and obtain technical and process information from the company so that this pyrolysis system can be thoroughly reviewed regarding its potential to process abattoir solid wastes at commercial scale.



### 3.4 Budget pyrolysis economics

Based on Bridle Consulting internal information and the data provided by the Australian pyrolysis provider companies, preliminary mass and energy balances will be developed for the processing of paunch waste plus DAF sludge and order of magnitude capital and operating costs/revenues will be defined for pyrolysis systems processing between 5 and 20 dry tonnes per day of these abattoir solid wastes. This data will be helpful in ascertaining whether waste pyrolysis is potentially a suitable technology for processing of abattoir solid wastes and thus whether Stage 2 of this project should proceed.

### 3.5 Develop a pyrolysis test programme

Based on the information gained from the Australian pyrolysis providers identified above, a pyrolysis test programme on paunch waste and DAF sludge, using pilot plants and/or batch laboratory systems will be developed.

## 4 Results and discussion

### 4.1 Pyrolysis overview

Waste pyrolysis, also called carbonisation, is universally regarded as a process where waste is heated indirectly, in the absence of oxygen, to a temperature of between 350 and 500 °C. Under these thermal conditions the waste decomposes and about 30 to 60% of the dry mass is volatilised to produce a crude syngas with the remaining solids converted to a char product. In essence, pyrolysis is the thermal destructive distillation of organic materials. Traditionally the pyrolysis syngas is condensed to generate oil, produced water and a non-condensable gas (NCG). The process is endothermic and requires about 1 to 1.5 GJ of thermal energy per tonne of dried waste processed. Unlike gasification, which involves some combustion of the feedstock, pyrolysis involves NO combustion and consequently the products contain all of the chemical energy that was present in the original waste material. A process schematic of waste pyrolysis, showing the various process configurations and product end-use options is shown in Figure 4.1.

Pyrolysis converts complex organic molecules to simple gases, producing organic vapours, synthesis gases and a char product containing the remaining elemental carbon, non-volatilised metals and other inert material in the feedstock (ash). The products of pyrolysis always comprise gas, liquid and solid char with the relative proportions of each depending on the feedstock, method of pyrolysis and the reaction parameters, such as time, temperature and pressure. Lower temperatures produce more liquid product and high temperatures produce mostly syngas. However subsequent processing can convert one to another as is shown in the pyrolysis schematic in Figure 4.1.

Pyrolysis can be characterised as “Fast Pyrolysis” or “Slow Pyrolysis”. Fast pyrolysis occurs in a matter of a few seconds or less and decomposes organics to mostly vapours, aerosols and some charcoal. Fast pyrolysis maximises the production of syngas and liquid products. Slow pyrolysis requires a slow reaction time, typically hours or even days, at low temperatures (less than 500 °C) to maximise the yield of solid char. A typical example of slow pyrolysis or carbonisation is the production of charcoal from wood and wood waste, as has been practiced by ancient civilizations for many millennia.

Figure 4.1: Pyrolysis Process Schematic

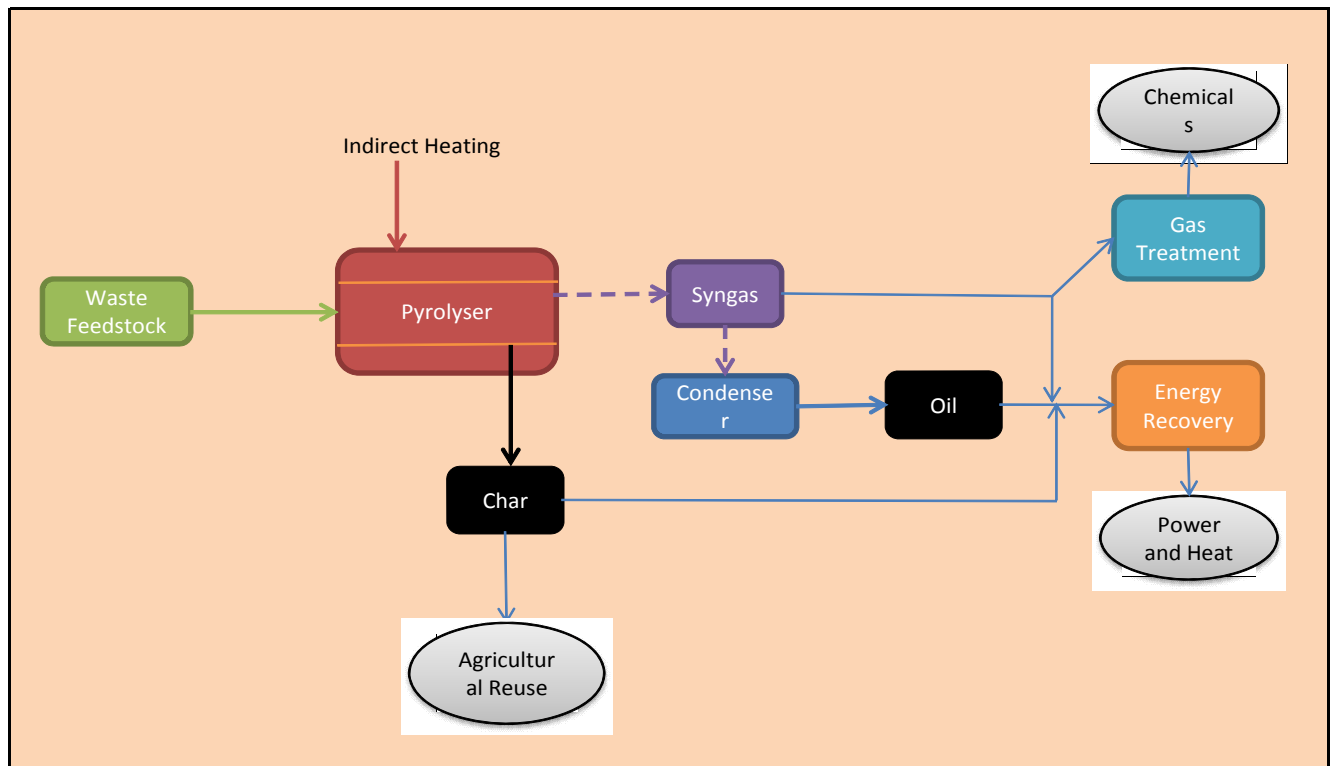

### 4.1.1 Fast or flash pyrolysis

Fast or flash pyrolysis is used to maximise either gas or liquid products. In fast pyrolysis, the organic materials are rapidly heated to 450 - 600 °C in the absence of air, for a process time of a few seconds or less (heating rates of up to 1000 °C/sec). Under these conditions, pyrolysis gases, organic vapours, and a little char are produced.

The gas is of a medium heating value (13-21 MJ/Nm<sup>3</sup>). The vapours are subsequently condensed to produce liquids ("pyrolysis oil" or "bio-oil" if the substrate is biomass). These oils are very complex mixtures of hydrocarbons, which can be upgraded for conversion to chemicals, power or heat.

While related to the traditional slow pyrolysis processes for making charcoal, fast pyrolysis is an advanced process, with carefully controlled parameters to give high yields of liquids. Fast pyrolysis is a relatively new process made possible by recent engineering advances in reactor design<sup>1</sup>. The essential features of fast pyrolysis process are:

- Very high heating and heat transfer rates at the reaction interface, usually requiring finely ground feedstocks;
- Carefully controlled reaction temperatures of ~ 500 °C and vapour phase temperatures of 400-450 °C;
- Short vapour residence times of typically less than 2 seconds;

<sup>1</sup> Bridgewater, A. V., "Fast Pyrolysis of Biomass: Technical Requirements for Commercialisation", Proceedings of the Expert Meeting on Pyrolysis and Gasification of Biomass and Waste, Strasbourg, France, 2002.

- Rapid cooling of the pyrolysis vapours to produce the bio-oil product.

Fast pyrolysis is probably not the preferred process for non-homogeneous wastes such as abattoir wastes due to the need for finely ground and uniform quality feedstocks. One of the most advanced fast pyrolysis systems is that supplied by the Canadian company, Dynamotive Technology Corporation. Renewable Oil Corporation in Melbourne has the Australian and NZ rights to the Dynamotive technology.

### 4.1.2 Slow pyrolysis

Slow pyrolysis has traditionally been used for the production of charcoal. Slow pyrolysis (or carbonisation) requires a slow reaction, longer residence times (~30 seconds for gas phase, 30-60 minutes or even longer for solids) at low temperatures (typically 450 °C or lower) to maximise the yield of solid char. Its main advantages over fast pyrolysis include:

- Higher reaction times and surface areas are available for heat and mass transfer;
- A simpler process (batch or semi continuous) enabling use of less sophisticated equipment and easier controls;
- Potential to process less uniform or larger size feedstocks compared with fast pyrolysis; and
- Higher char yield.

In many less developed countries such as India, Indonesia, Malaysia and Sri Lanka, simple batch retorts are used as slow pyrolysis systems to generate charcoal from wood and agricultural residues, particularly coconut shells. Much of this charcoal is activated to produce high grade activated carbon that is used extensively in the gold industry in their carbon-in-pulp recovery processes.

In the past few decades numerous companies have developed more sophisticated slow pyrolysis systems designed to process various waste streams including wood waste and agricultural residues, industrial and clinical wastes, the organic fraction of Municipal Solid Waste (MSW), industrial sludge, plastics and sewage sludge. In Australia there are a number of companies who have developed or are developing slow pyrolysis systems and a listing of these companies is shown below:

- Environmental Solutions International Ltd (ESI). They developed and patented the EnerSludge™ process for the pyrolysis of sewage sludge and a commercial 25 tonne per day (tpd) demonstration plant was operated for about 2 years at the Subiaco wastewater treatment plant in Perth. ESI went into liquidation in 2004 and the technology is no longer available in Australia.
- BEST, now Pacific Pyrolysis in NSW who have developed a range of slow pyrolysis processes aimed at conversion of wood and agricultural wastes to char.
- Black is Green Pty Ltd of Mackay who have developed the BigChar process.
- Anthrotterra Pty Ltd of Sydney.
- Crucible Carbon of Newcastle who have a 100 to 400 kg/h pilot plant available for test-work.
- Biochar-Energy System Pty Ltd.
- Chaotech Pty Ltd of Rocklea, QLD who have a 60 kg/h pilot plant available for test-work.
- Entech Pty Ltd of Jandakot, WA who offer commercial gasification and pyrolysis systems.

- CSIRO Forestry and Forest Products who are developing a slow pyrolysis system in Melbourne.

There are also a number of overseas companies who offer commercial slow pyrolysis systems and the major players are shown below:

- Thide Environnement of France;
- WasteGen of the UK;
- Compact Power of the UK;
- ZWT Wasser und Abwassertechnik GmbH of Germany; and
- Choren of Germany who supply slow pyrolysis and integrated pyrolysis/gasification systems.

### 4.1.3 Pyrolysis reactor configurations

#### **Rotary kiln reactors**

Many pyrolysis and gasifier vendors offer this reactor design, predominately for the processing of municipal solid waste (MSW), wood waste, green waste and industrial/clinical wastes. Solid wastes are fed into a tightly sealed air/oxygen free rotary kiln heated indirectly to temperatures of 400-600 °C and providing solids retention times of about 30 to 60 minutes. Gas retention times vary, but are typically 20 to 60 seconds. This reactor type offers good heat transfer due to the good solids mixing within the kiln. Typically feedstock particle size can be up to 10 mm.

#### **Tubular reactors**

Quite a number of vendors offer these stationary tubular reactors with conveying/mixing elements within the tube for solids transport. An annulus around the reaction tube is used for indirect heating, usually using hot air. The reactor configuration is less complex than rotary kilns since there are no rotary seals required and maintenance of an oxygen-free environment is thus easier. However, without good mixing elements within the reactor, heat transfer can be limiting. To eliminate heat transfer limitations feedstock particle size is normally limited to about 6 mm. Solids and gas retention times are similar to those of rotary kiln reactors.

#### **Fluid bed reactors**

Fluid bed reactors tend to be used when fast or flash pyrolysis is practised as they provide much higher heating rates and give good and consistent performance with high liquid yields. The feedstock must be relatively small, in the order of 2-3mm to achieve the high biomass heating rates. The residence time of solids and vapour is controlled by the fluidising gas flow rate and is higher for char than vapours. As char is an effective vapour cracking catalyst at fast pyrolysis reaction temperatures, rapid and effective char separation/elutriation is important after the gas exits the fluid bed. Typically gas retention times are less than 5 seconds. Most fluid beds are heated indirectly via heat transfer tubes in the bed.

#### **Circulating fluid bed reactors**

These similar to the fluid bed reactor except that the residence time for the char is almost the same as for vapours and gas due to high gas recirculation rates around the bed. There are few if any commercial reactors of this type. As with fluid bed reactors feedstock particle size is normally limited to about 2 mm.

### 4.1.4 Pyrolysis feedstock quality issues

The characteristics of the waste being pyrolysed have a major impact on product yields and quality. Fundamental pyrolysis studies have indicated that wastes high in carbohydrates and cellulose tend to produce mostly char and wastes high in lipids and proteins tend to produce high gas and liquid yields<sup>2</sup>. Thus paunch wastes are likely to produce mostly char while DAF sludge would produce a high gas yield. The contaminant levels in the waste will also affect product quality. Non-volatile material such as sand, silt, clay and most heavy metals will be retained in the char. It has been demonstrated that mercury is completely vaporised and is thus transferred to the gas. If the gas stream is condensed to oil, most of the mercury is retained in the solids removed from the oil by centrifugation<sup>3</sup>. The pyrolysis process essentially destroys organochlorine compounds via dehalogenation. Studies have revealed that up to 85% of compounds such as PCBs and Hexachlorobenzene are destroyed<sup>3</sup>.

Typically the TS of the feed to a pyrolysis system is greater than 85%. This is to minimise energy consumption in the pyrolyser (heat of vaporisation of the water and the sensible heat to raise the steam to the operating temperature) and also to ensure that the syngas has a reasonable heat value (ie, is not too much water vapour with no energy). The particle size of the feedstock is also important. For rotary kiln and tubular reactors particle size is usually limited to 10 mm in size and for fluid bed systems to 2 to 3 mm in size.

### 4.1.5 Commercial waste pyrolysis systems

There are no commercial waste pyrolysis systems operating in Australia but there are systems operating in Europe, the US and Japan. The only waste pyrolysis system that has operated in Australia was the Subiaco WWTP sludge pyrolysis facility in Perth, WA. This facility was based on the ESI Enersludge technology, a slow pyrolysis process using two tubular reactors in series with screw conveyors for solids transport in the reactors. The facility was designed to process 25 dry tpd of sewage sludge and operated for about 2 years before being shut down by the client (Water Corporation of WA) due primarily to cost considerations. Detailed operational results from this facility have been documented previously<sup>4</sup> but a summary of the product yields and energy values is shown in Table 4.1. A photo of the reactors is shown in Figure 4.2.

**Table 4.1: Sewage Sludge Pyrolysis Results**

Product	Yield (%)	Energy Content (MJ/kg)	Percent of Sludge Energy
Char	43	18	40
Oil	29	30	45
Non-condensed gas	14	15	11
Reaction water	13	6	4

<sup>2</sup> Bridle, T.R., "Sludge Derived Oil: Wastewater Treatment Implications", *Env. Tech. Letters*, Vol 3, 1982.

<sup>3</sup> Bridle, T.R., I. Hammerton and C.K. Hertle, "Control of Heavy Metals and Organochlorines using the Oil from Sludge Process", *Wat. Sci. Tech. Vol 22, No 12*, 1990.

<sup>4</sup> Bridle, T.R and JM Rovel, "Full-Scale Application of Sewage Sludge Pyrolysis: Experience from the Subiaco Plant in Australia", *Proceedings of the Expert Meeting on Pyrolysis and Gasification of Biomass and Waste*, Strasbourg, France, 2002.

Figure 4.2: Photo of the Subiaco Sludge Pyrolysis Reactors

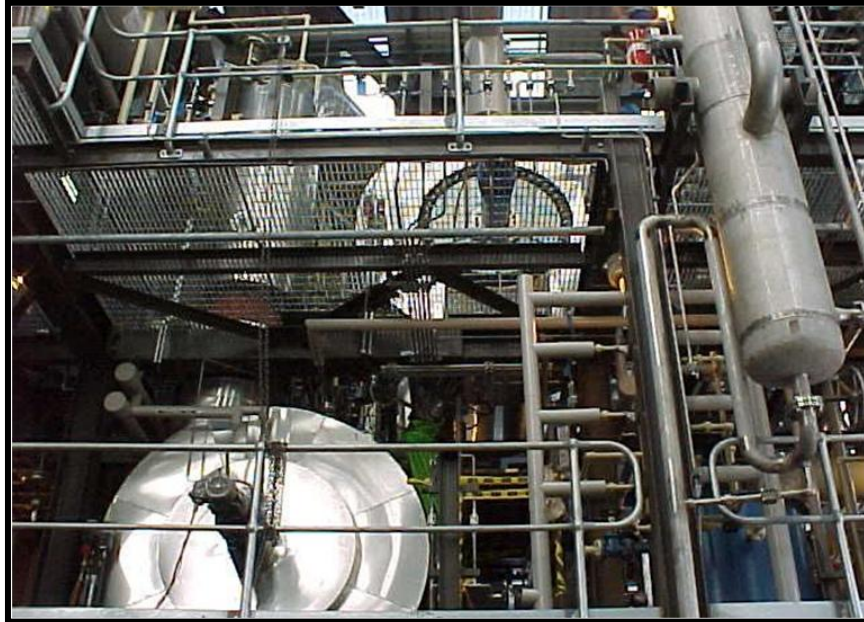

Thide Environnement of France, in association with Institute Francais du Petrole has developed a slow pyrolysis process called EDDITH<sup>5</sup>. This process is based on the use of rotary kiln reactors and there is one commercial facility operating in France and two in Japan, built by the Thide licensee, Hitachi Corporation. All of the facilities process predominately MSW with small amounts of industrial wastes and sewage sludge. A schematic of the EDDITH process is shown in Figure 4.3.

Figure 4.3: Schematic of the EDDITH Pyrolysis Process

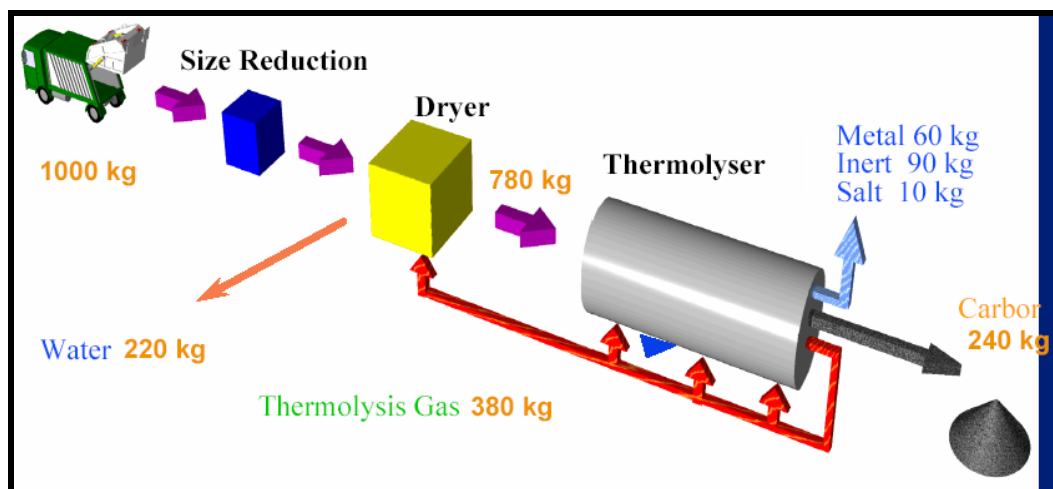

<sup>5</sup> www.thide.com

The waste is first sorted (blue box), then dried before being pyrolysed in the rotary kiln. The kiln raises the dried feedstock temperature to between 400 and 700 °C with a solids retention time of between 30 and 60 minutes. Heating rates are 10 to 50 °C/minute. The syngas is usually used to dry the feedstock and provide the process heat to the pyrolyser as shown in this flow sheet. Any excess is usually used to raise steam. The end char product, called Carbor is usually used as a fuel in other processes, such as cement kilns. Inerts, salt and metals are removed from the char by washing. The first commercial facility commenced operations in Arras in France in 2003, processing 50,000 tpa of MSW, industrial waste and sewage sludge. Syngas yield is 49% and the refined char yield is 31%. This indicates the capital cost of the facility was €22 million and operating costs are €85/t. Two more plants are operating in Japan in Itiogawa (25,000 tpa) and in Izumo (70,000 tpa), both processing predominately MSW. A picture of the rotary kiln at the Izumo plant is shown in Figure 4.4.

**Figure 4.4: Photo of the EDDITH Rotary Kiln at Izumo, Japan**



WasteGen Ltd of the UK and their German technology provider Tech Trade GmbH has supplied many solid waste pyrolysis facilities that are based on the use of rotary kiln technology<sup>6</sup>. One of their best known facilities has been operating in the German town of Burgau since 1987. This plant processes about 36,000 tpa of mainly MSW, with small amounts of industrial wastes and some sewage sludge. In this facility MSW is pyrolysed at 600 °C with the char/ash separated from the gas and materials such as metals removed for recovery. The pyrolysis gas is combusted at 1250 °C and the hot flue gas used to provide the process heat to the carboniser and excess heat converted to steam to drive a steam turbine for power generation. The facility produces 2.2 MW of electricity. A schematic of this facility is shown in Figure 4.5. In 2001 WasteGen built a much larger MSW pyrolysis plant in the German town of Hamm. This facility operates two pyrolysis lines each with its own rotary kiln. The plant has a design capacity of 100,000 tpa and cost £50 million. The plant input is 13 tph and the outputs include 10.3 tph of syngas and 2.5 tph of char. The syngas is combusted and electricity is produced via steam

---

<sup>6</sup> [www.wastegen.com](http://www.wastegen.com)

turbines. Electrical output is 8.3 MW. This facility is owned and operated by the German utility company RWE.

Figure 4.5: Schematic of Burgau Waste Pyrolysis System

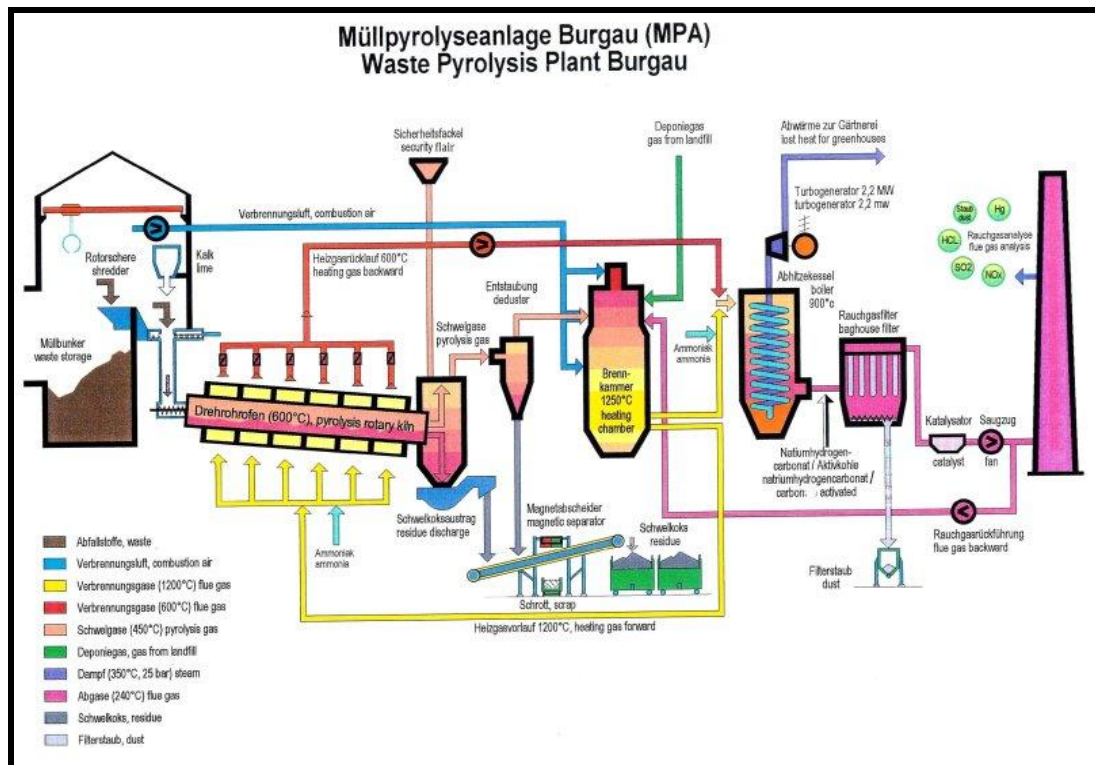

Compact Power operates a pyrolysis/gasification plant at Avonmouth in the UK, processing mainly clinical waste<sup>7</sup>. Their process involves pyrolysis in a tubular reactor with a conveyor to move the material along the length of the reactor. The char and syngas is gasified and then combusted to produce steam, which is then converted into electricity in a steam turbine. The ash from the char gasifier is land-filled. A schematic of this plant is shown in Figure 4.6.

ZWT Wasser und Abwassertechnik (ZWT) GmbH is a relatively small German company specialising in wastewater treatment and sludge management. In 2003 ZWT entered into a technology development programme with ESI in Perth WA, to improve and simplify the patented ESI Enersludge process. Unfortunately in 2004 ESI went into liquidation and ZWT continued the technology development programme alone. A very simple tubular pyrolysis reactor system was developed and connected to an off-the-shelf hot syngas combustor, providing a simple integrated pyrolysis system. A commercial 6 tpd (2000 tpa) facility was built in 2007/08 and has been operating at the sewage treatment plant (Pfattertal) in the town of Mintraching, Germany since 2009. This facility processes dried sewage sludge<sup>8</sup>. This pyrolyser is a tubular reactor with mixing and conveying elements within the reactor. A picture of the pyrolyser is shown in Figure 4.7 and a process flow diagram in Figure 4.8.

<sup>7</sup> Hogg, R., "Energy from Waste by Pyrolysis and Gasification: Experiences and Performance of an Operational Plant", Proceedings of the International Conference on Sustainable Waste Management, Chennai, India, 2007.

<sup>8</sup> Personal communication, Dr S. Skrypski-Mantele, contractor to ZWT, 2010.



Figure 4.6: Schematic of the Compact Power Plant

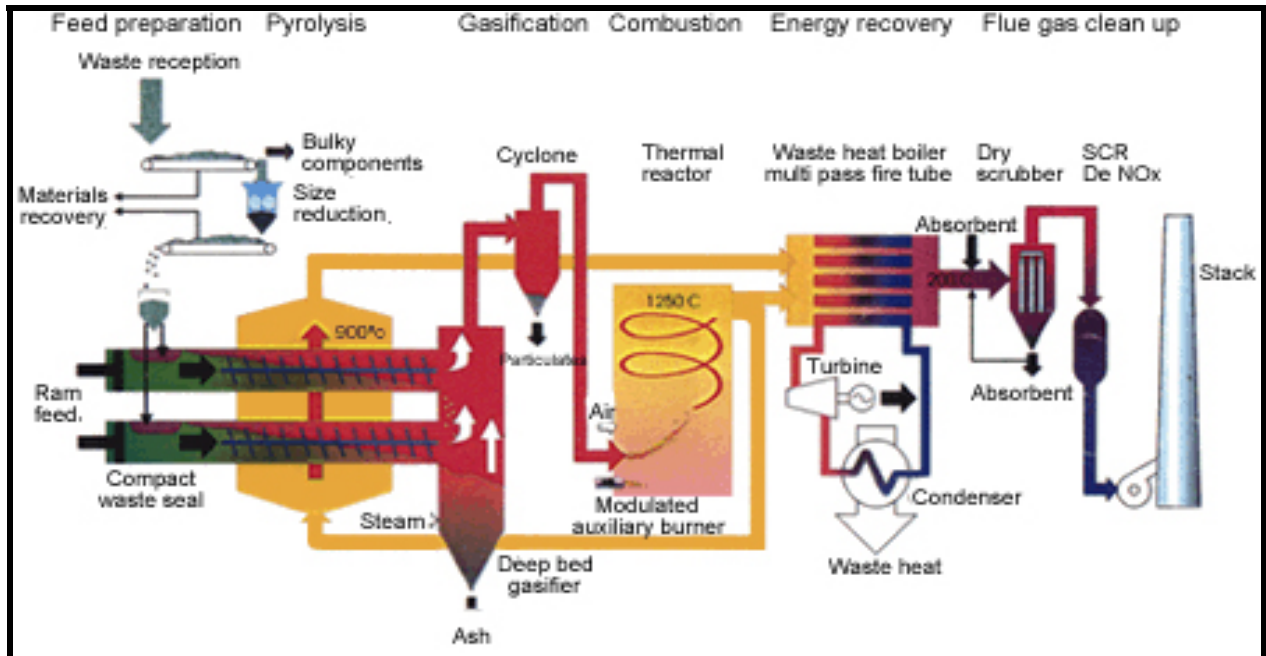
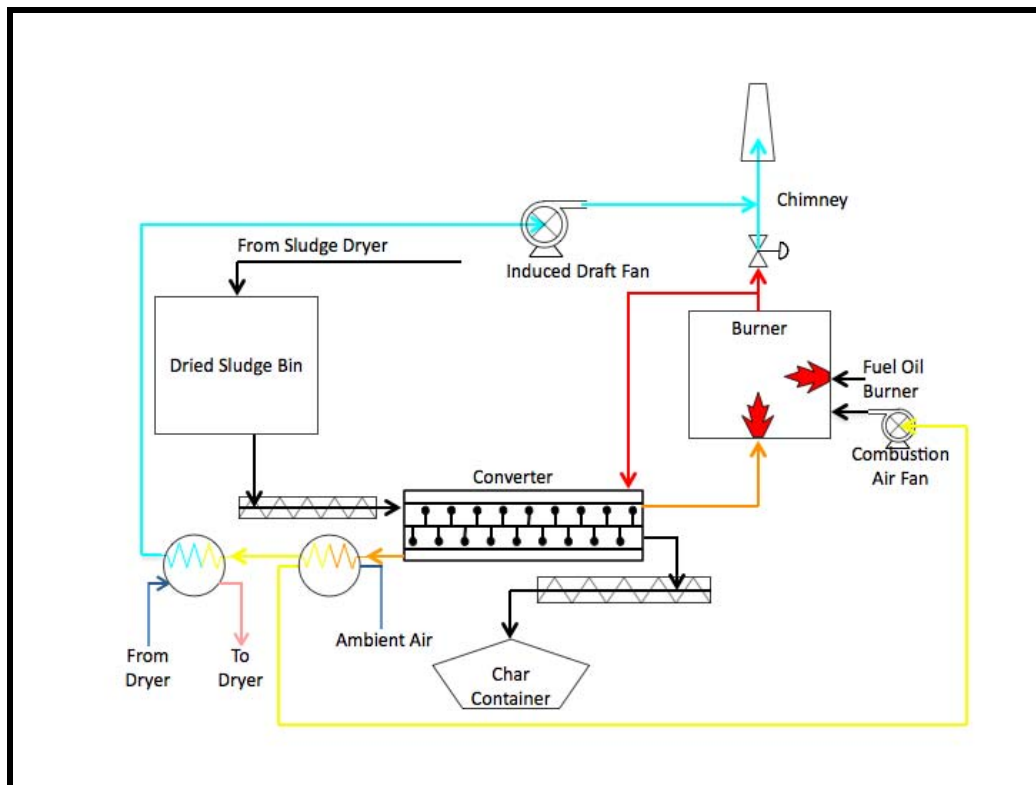

Figure 4.7: ZWT Pyrolyser at Mintraching, Germany



Figure 4.8: PFD of ZWT Pyrolysis System



As can be seen the syngas from the pyrolyser is combusted to provide the energy for drying the sludge and heating the reactor. The char (yield is 65% of sludge feed) is sold to a local brick-works for the production of light-weight insulating bricks.

Choren Industries of Germany has been involved in the pyrolysis and gasification of waste for many years, specialising in wood wastes and more recently in virgin wood chips. Over the past 20 years Choren have developed and fine-tuned their Carbo-V pyrolysis/gasification technology, which now includes a Fischer-Tropsch synthesis system, to convert the syngas to liquid fuel (diesel). Their demonstration Biomass-to-Liquids (BtL) plant at Freiberg is designed to process up to 68,000 dry tpa (186 tpd) of forestry residues to produce 18,000 m<sup>3</sup>/a of diesel and 45 MWth of energy as waste heat<sup>9</sup>. The process starts with pyrolysis of the shredded solid wood waste at 500 °C to produce a pyrolysis gas and char, which are then gasified with oxygen at 1400 °C to produce a high quality syngas with essentially no tars. This is then converted to diesel using a Fischer Tropsch Synthesis unit. The plant is reported to have cost €100 million. Data on the economics of the operating plant are not yet available and it appears that technical difficulties are delaying start-up of the facility. This was reported in the Jan 2009 E-Energy Market Report<sup>10</sup>. A photo of the facility is shown in Figure 4.9.

<sup>9</sup> www.choren.com

<sup>10</sup> www.e-energymarket.com

Figure 4.9: Choren BTL Plant

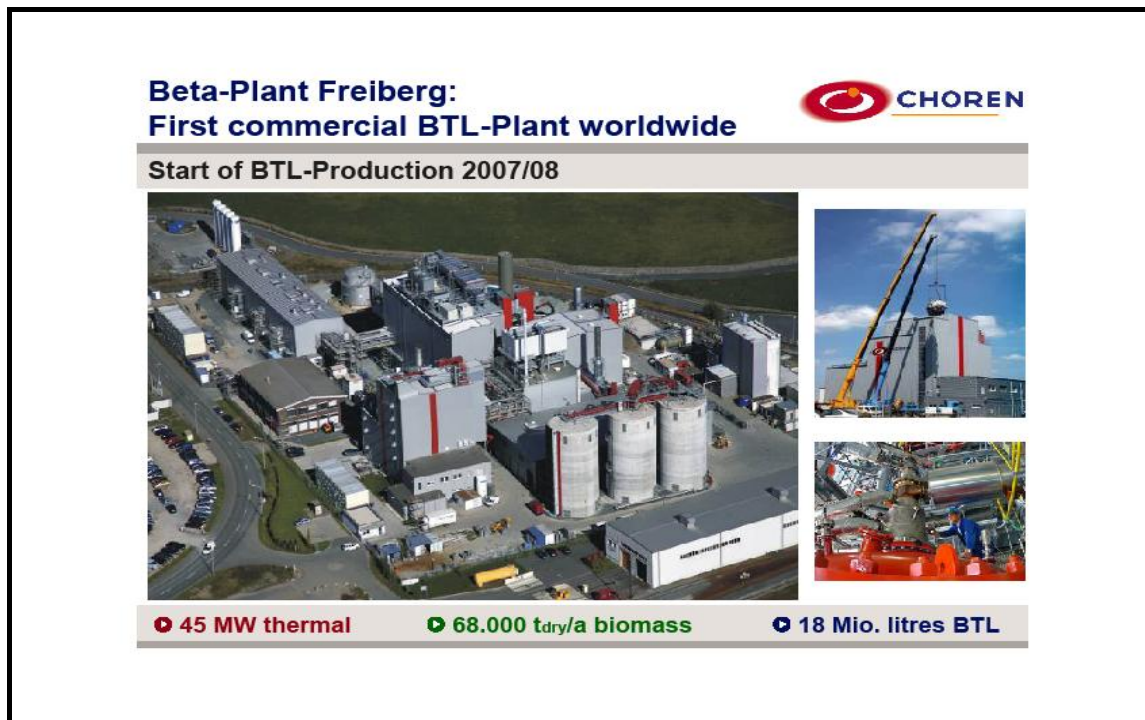

### 4.1.6 Pyrolysis experience with abattoir solid wastes

A search of the literature has revealed essentially no documented cases on the pyrolysis of abattoir solid wastes. The only information that has been obtained is internal ESI data on the pyrolysis of meat and bone meal (MBM) and data reported on the thermal depolymerisation of turkey offal. In 2003 ESI conducted continuous laboratory scale pyrolysis experiments on a number of organic wastes including dried MBM<sup>11</sup>. The MBM had a volatile solids (VS) content of 83% and a gross calorific value (GCV) of 21 MJ/kg. Pyrolysis at 450 °C produced a char yield of 41%, oil yield of 26%, water yield of 23% and non-condensed gas yield of 10%.

In 2004 the US company Changing World Technologies (CWT), through its subsidiary, Renewable Environmental Solutions (RES) commenced operation of its Thermal Depolymerisation (TDP) facility in Carthage, Missouri<sup>12</sup>. This facility was designed to process 78,000 tpa (200 tpd) of turkey offal into oil, gas, carbon and fertiliser. The feedstock, as a slurry, with a nominal TS of 49% is processed under high pressure (40 bar) and temperatures of up to 500 °C in a dual aqueous reactor system. This can be regarded as high pressure aqueous pyrolysis, which CWT calls TDP. A picture of the plant is shown in Figure 4.10 and a summary of the design inputs and outputs for the facility is shown in Figure 4.11.

<sup>11</sup> Internal ESI documents from Trevor Bridle

<sup>12</sup> Adams, T.N. et al, "Converting Turkey Offal into Bio-derived Hydrocarbon Oil with the CWT Thermal Process", Proceedings of the Power-Gen Renewable Energy Conference, Las Vegas, 2004.

**Figure 4.10: Photo of the CWT TDP Plant**



The capital cost of the plant was originally estimated at \$US 15 million but the final cost was nearly \$US40 million. The plant was designed to produce oil at a cost of \$US 15/barrel but actual costs were \$US80/barrel. As can be seen from Figure 4.11 the facility was designed to produce nearly 70 tpd of oil equivalent to yield of 68% of the dry feed. The oil was designed to contain nearly 81% of the energy of the offal fed to the system. The plant however never met these design values and in 2009 CWT closed the facility and filed for bankruptcy protection under the US "Chapter 11" system<sup>13</sup>. Prior to 2009 the plant had been shut down many times by the regulator in Missouri due to odour issues. No additional information on the status of CWT has been able to be sourced via the internet.

---

<sup>13</sup> [www.freshare.net/print\\_article/5643/](http://www.freshare.net/print_article/5643/)

Figure 4.11: Design Inputs and Outputs for the CWT TDP Plant

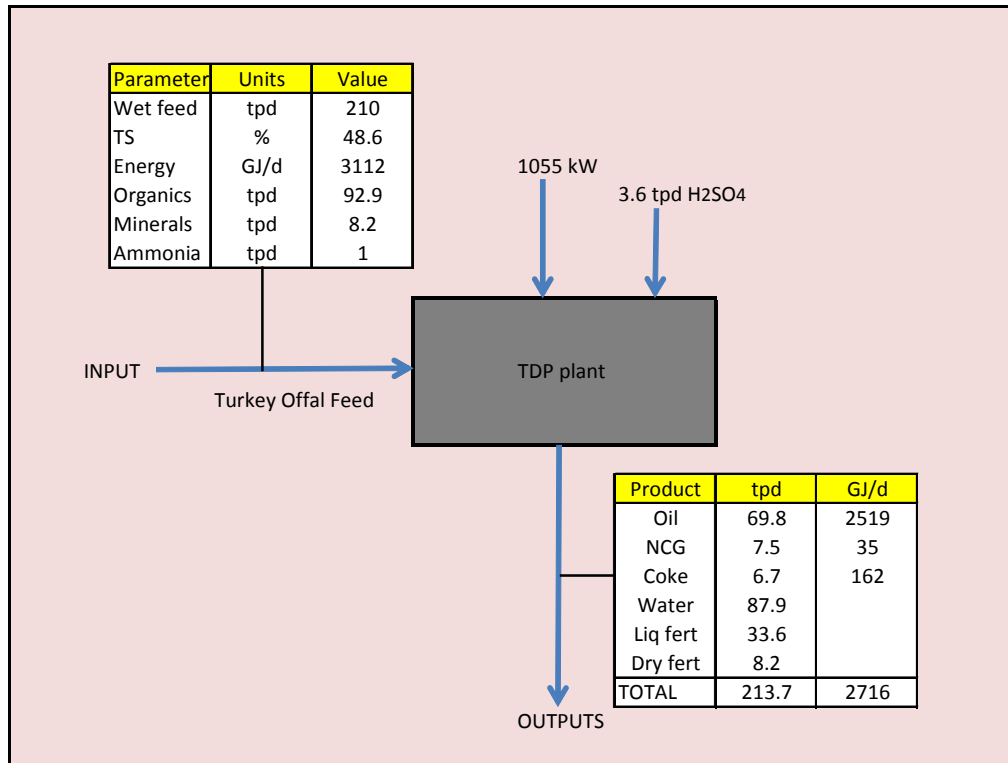

## 4.2 Review of Australian pyrolysis systems

An internet search for Australian pyrolysis vendors has identified eight companies who offer pyrolysis processes. These companies are identified below:

- AnthroTerra Pty Ltd of Somersby, NSW,
- Biochar-Energy Systems Pty Ltd of Bendigo, VIC,
- Black is Green Pty Ltd of Mackay, QLD,
- Chaotech Pty Ltd of Rocklea, QLD,
- Crucible Carbon Pty Ltd of Sydney, NSW,
- New Energy Corporation Pty Ltd of Perth, WA,
- Pacific Pyrolysis Pty Ltd of Somersby, NSW, and,
- Renewable Oil Corporation Pty Ltd of Surrey Hills, VIC.

All of these companies were sent a questionnaire which was aimed at obtaining relevant information to allow a preliminary assessment of their company and pyrolysis process. The information received from these vendors is summarised below.

### 4.2.1 AnthroTerra P/L process

AnthroTerra is a private company established to develop and commercialise biochar technologies. The two principals are Dr Stewart McGlashan and Dr Steve Joseph who established BEST, the forerunner to Pacific Pyrolysis, many years ago. The AnthroTerra pyrolysis system is based on the use of indirectly heated rotary kiln technology. They have three major equipment development programmes underway. A 150kg/h (char output) portable

continuous pyrolysis system, a 1 tph fixed system and a 2 tph fixed system. All these systems are to be ready for commissioning in September or October 2010. The AnthroTerra approach is to customise the pyrolysis system to meet customer requirements. All systems are very flexible and can operate at temperatures of between 400 and 600 °C and solids retention time and additives can be varied to meet required char properties. The main AnthroTerra focus is on the production of chars to be used to improve soil fertility. A picture of an AnthroTerra pyrolysis system is shown in Figure 4.12.

**Figure 4.12: Picture of AnthroTerra Pyrolysis Unit**



### 4.2.2 Biochar-Energy Systems P/L process

Most of Biochar-Energy Systems work to date has been on poultry litter done in conjunction with the Northern Poultry Cluster in Bendigo. This work has been done using a 200 kg/h pyrolysis unit. The BES process is based on an Inclined Ablative Tubular Screw system. It is a dual reactor system, the first stage being a combined pre-drier and early stage torrefaction. The second stage is where the pyrolysis reaction takes place. Multiple gas extraction points are a feature of the system. Water and heavy condensables are removed separately from the latter stage pyrolysis syngas leading to a "cleaner" combustible syngas, and various condensate streams. It is a continuous slow pyrolysis process operating at between 480-550 °C with a residence time of 20 minutes. Biochar yields for woody biomass is around 30-35% and for poultry litter around 38-39%. With a feed stock moisture content at around 25% and a calorific value around 18MJ/kg, the process consumes 40% of the syngas produced to maintain the reaction. Condensate (oil) yields are generally on a par with the biochar yield. In conjunction with their American partner, Genesis Industries of California, BES will be further assessing the production and end-uses of the bio-oil product. A picture of the 200 kg/h unit is shown in Figure 4.13.

**Figure 4.13: Picture of 200kg/h BES Pyrolysis System**



### 4.2.3 Black is Green P/L process

Black is Green P/L (BiG) is a small Queensland company that was established in 2009 to commercialise the intellectual property (IP) associated with the BiGchar process that was developed as a follow-on from the PhD dissertation submitted by Dr Joyce in 2006. Drs James and Stan Joyce developed the technology and are the owners of the technology. The company is currently funded by two investors and BiG is currently seeking additional working capital via the venture capital markets.

The BiGchar process is actually a gasification technology as the process heat required is provided by combustion of some of the feedstock. The process could be called a moving-bed updraft gasifier but the technology itself is a novel application of the conventional multiple hearth furnace technology that has been used for decades to calcine, combust and dry materials. In essence the reactor is a vertical tube with multiple hearths and rabble arms mounted on the central shaft which rotates to move the material from hearth to hearth. As the material moves downward from the top of the gasifier its temperature increases and pyrolysis occurs. The air required for limited combustion to raise the feedstock to about 400 °C is provided by a natural updraft ventilation system. The char discharges from the bottom of the vessel where there is essentially no oxygen. The char is sprayed with water as it exits the reactor to prevent combustion. The syngas exits from the large stack at the top of the reactor that creates the draft in the reactor. The ventilation rate is controlled by dampers on the side of the reactor. Currently the syngas is combusted in this stack but plans are underway to burn the syngas in engines for power production. A picture of the original developmental unit is depicted in Figure 4.14 which shows the truck-mounted gasifier, the large natural ventilation stack, the feed conveyor and char discharge conveyor.

**Figure 4.14: The Original BiGchar Gasification Reactor**



BiG have three pyrolysis units, a 1000 mm diameter test unit, the original 1800 mm diameter unit and a newer 2200 mm diameter industrial standard unit. The development and fabrication of the 2200 unit was partially funded under a Queensland Sustainable Energy Innovation Fund grant. BiG is a finalist in the Queensland Premier's ClimateSmart Technologies Award programme. A picture of the 2200 unit is shown in Figure 4.15.

BiG has been conducting developmental trials using their 1800, 2200 and 1000 units since early 2009. They have experience processing sugarcane trash, green waste and sawdust. The major aims of the trialling have been to produce char for agri-testing and also mechanical reliability testing and refinement. According to BiG, they can accept waste with a moisture content of up to 40% or a TS of greater than 60%, but unit throughput is reduced as the moisture content increases. They have just secured a contract to send a 1000 unit to India for a soil fertility project.

BiG have developed an extensive char yield and quality data base for all the wastes they have tested. Gas yield and energy content is determined by difference. There is very limited data on the quality of the combusted off-gas from the system. Based on their data base BiG have estimated that if combined DAF sludge and paunch waste, with a VS of 86% and a TS of 80% were processed, it would generate a char yield of 26.5% on a dry weight basis. A simple Mass and Energy balance for the processing of a nominal 18 dry tonnes per day of paunch waste and DAF sludge, as estimated by BiG, is shown in Figure 4.16.

**Figure 4.15: Picture of the BiGchar 2200 Unit**





As can be seen BiG estimate that 4.78 tpd of dry char would be generated and if the gas is combusted in a gas engine 275 kW of power would be generated. These estimates are based on the assumption that the feed is dried to a TS of 80% prior to thermal processing. The waste heat from the gas engine would only supply about 35% of the thermal energy required to dry the material. BiG have estimated the capital cost of such a facility (excluding the dryer) would be about \$1 million. One 2200 Gasifier Unit is required for this duty.

Figure 4.16: BiGchar M&E Balance

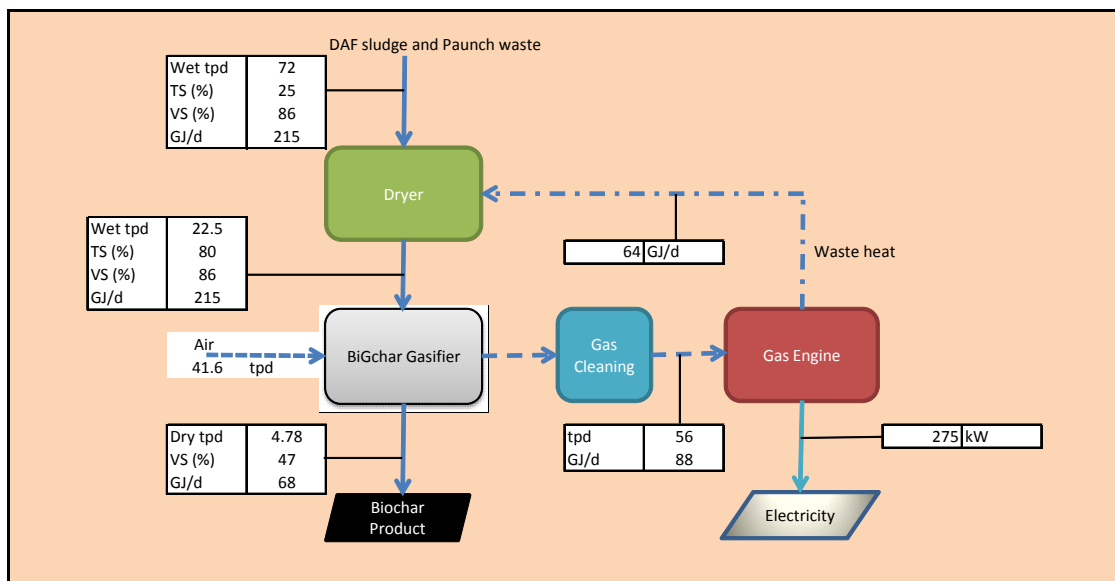

### 4.2.4 Chaotech P/L process

Chaotech is a Queensland engineering and equipment manufacturing company who have developed their pyrolysis process under co-funding from the Federal Government Climate Ready Programme. They are in the final stages of demonstrating the process on a 140 kg/h pilot plant. Once acceptable operations are achieved on the pilot plant they are obligated to build a 20 tpd plant under their Federal Government Climate Ready programme funding. The technology is based on use of indirectly heated rotary kilns which operate at high pressure (10 bar) and temperatures of between 400 and 450 °C. Their pilot plant includes a rotary kiln dryer, a rotary kiln pyrolyser and a rotary kiln char cooler, a syngas condensing system (to produce bio-oil) and an engine for power generation. A picture of the pilot plant at their Rocklea facilities is shown in Figure 4.17.

Most of the trials conducted to date have been on finely ground sawdust with a moisture content of about 30%. The residence time at temperature in the pyrolyser is about 10 minutes. Under these conditions the facility generates a char yield of about 40% on a dry weight basis. In addition 30kW of electricity is generated. Chaotech have filed a patent application to cover their process.

**Figure 4.17: Chaotech Pyrolysis Pilot Plant**



### 4.2.5 Crucible Carbon P/L process

Crucible Carbon had already responded to an earlier MLA request for information regarding piloting of MLA solid wastes in their pyrolysis equipment<sup>14</sup>. This letter indicated that their 100 to 400 kg/h pilot plant at Newcastle would be ideal for this work and Crucible Carbon provided a suggested testing programme. In 2008 Crucible Carbon commissioned a 100 to 400 kg/h pyrolysis pilot plant partially funded by the Federal Government Commercial Ready and COMET

---

<sup>14</sup> Letter from Crucible Carbon to MLA (Dr D Doral), dated 11 June, 2010.

programmes. They are currently designing and constructing a commercial module with the capacity of 8,000 to 10,000 dry tpa, aimed at the timber sawmill industry. This unit is scheduled to commence operations in 2010. A picture of their pilot plant is shown in Figure 4.18.

**Figure 4.18: Picture of Crucible Carbon Pyrolysis Pilot Plant**



The Crucible Carbon reactor is unique and has been patented<sup>15</sup>. It is a tubular reactor with a screw conveyor to move solids along the length of the reactor. The solids and air/oxygen/pyrolysis vapours/steam move counter-currently along the length of the reactor. The reactor is divided into five zones as shown in Figure 4.19. Crucible Carbon claim they can feed material with up to 50% water to the reactor, which is removed in Zone 1 as shown in Figure 4.19. Some of this water, which is highly contaminated with volatile organics, ammonia and sulphur compounds, is used to quench and densify the char in Zone 5. A feed TS of about 75% is required to ensure that there is no excess pyrolysis water from the system. Air or oxygen is injected into Zone 4 to combust some of the oil vapours which raises the temperature to about 600 °C in this zone. This process is thus partly gasification as some of the waste, in this case volatilised gas, is combusted to provide the process heat. As the waste solids move along the

---

<sup>15</sup> Crucible Carbon Patent, Processing Organic Materials, WO 2009/124359 A1, 15 October 2009.

length of the reactor their temperature increases to about 600 °C and the char is then cooled with water injection in the final zone of the reactor.

**Figure 4.19: Schematic of Crucible Carbon Reactor Configuration**

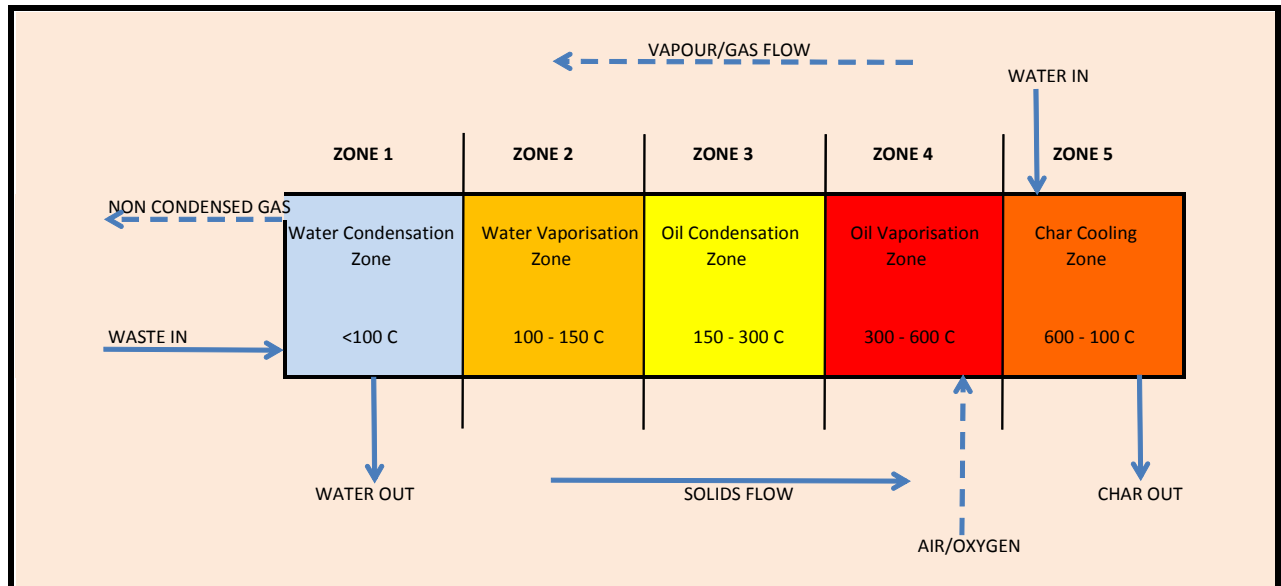

The reactor system can be operated in low or high gasification mode, depending on the amount of air or oxygen used. For a sawmill waste with a GCV of 20 GJ/t the syngas will contain 9 GJ/t of feed in low gasification mode which increases to 16 GJ/t feed when operating in high gasification mode. Char production is typically 35% of dry feed when operating on low gasification mode and decreases to 12.5% when operating in high gasification mode.

Crucible Carbon indicate that a 1 dry tph facility processing sawmill waste at a TS of 50% would generate 125kg/h of char and 1.8 MW of electricity when operating in high gasification mode. Waste heat from the engines would be used to dry the sawmill waste prior to pyrolysis. The capital cost of such a system, excluding the dryer is estimated to be about \$6 million.

### 4.2.6 New Energy Corporation P/L process

New Energy Corporation (NEC) is a new Perth-based private waste management company set up to integrate the extensive experience gained over 40 years by their principals to maximise energy recovery from waste and minimise waste to landfill. The company has the Australian and NZ rights to the Entech waste gasification technology, called WtGas-RES. Entech is a WA company headquartered in Jandakot and has sold over 100 of their waste gasification plants world-wide. These plants range in size from 3 to 60 tpd and process mostly clinical, pharmaceutical and e-waste, as well as MSW. The technology is very robust and is based on a moving-bed gasifier, syngas combustion unit and power generation module. The focus on the technology is to maximise gas production and hence minimise the amount of solid waste (char/ash) generated. A simple diagram of their WtGas-RES system is shown in Figure 4.20.

NEC plans only to offer plants with capacities of 60 tpd or greater and hence their systems will likely be too big for most Australian abattoirs. NEC plan to focus on MSW, commercial and industrial waste and construction and demolition waste.

Figure 4.20: Entech WtGas-RES Gasifier System

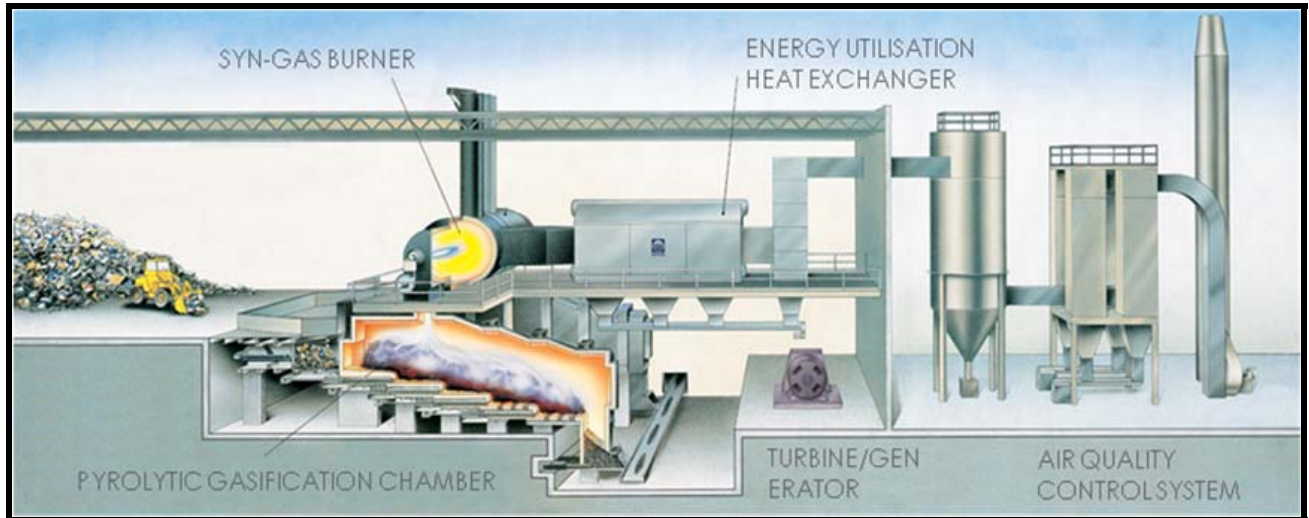

#### 4.2.7 Pacific Pyrolysis P/L process

Pacific Pyrolysis or PacPyro is a private company that was founded recently to exploit the slow pyrolysis technology developed by BEST Energies Australia Pty Ltd, a wholly owned subsidiary of BEST Energies Incorporated of the USA. PacPyro has the exclusive license to exploit the BEST pyrolysis technology in the Asia Pacific region, with the exception of India and China. PacPyro staff include many of the former BEST Energies Australia P/L staff and the company also bought the BEST Energies Australia facility in Somersby that includes all the pilot plant pyrolysis, drying, gas cleaning and power generation demonstration equipment that make up an integrated pyrolysis system.

The BEST pyrolysis technology is based on use of an indirectly heated stationary kiln which operates at only a few kPa above atmospheric pressure. The kiln is agitated internally to move the material along its length. Pyrolysis temperatures are typically 400 to 500 °C. The technology includes syngas cleaning, char activation/gasification and gas engines for power generation. A schematic of an integrated BEST Pyrolysis system is shown in Figure 4.21.

As can be seen from Figure 4.21 there is significant reuse of energy streams in an integrated facility. The crude syngas from the pyrolyser and the char conditioner are refined in proprietary gas cleaning equipment to produce gas suitable for use in gas engines.

PacPyro has a wealth of experience with processing a variety of wastes including green waste, wood wastes, bagasse, paper mill sludge, municipal sewage sludge, animal manure, crop residues and MBM. The pyrolysis kiln can accept waste up to 40 mm in size but the TS must be 70% or higher, hence the integrated dryer system. PacPyro have a variety of pilot plant equipment at Somersby including batch and continuous systems, what would be suitable for testing of paunch wastes. In June 2010 PacPyro provided a recommended testing program to MLA<sup>16</sup>. A picture of the PacPyro 300 kg/h pilot plant at Somersby is shown in Figure 4.22.

<sup>16</sup> Letter from PacPyro to MLA (Dr D Doral), dated 2 June, 2010.

Figure 4.21: Integrated BEST Pyrolysis System

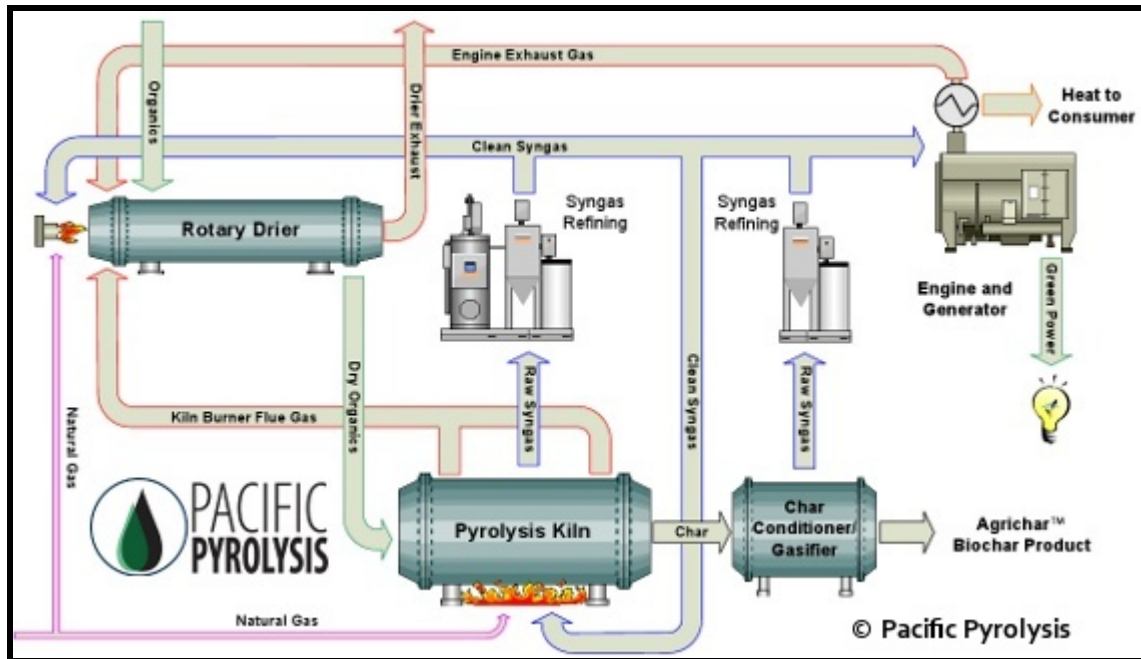

PacPyro have developed designs for 2 and 4 tph integrated pyrolysis facilities and with partner Transfield Services now offer these units as commercial plants, providing the client with a low risk facility.

PacPyro was unable to provide any specific process or commercial data on their pyrolysis system for the processing of paunch waste as this could only be done once pilot testing of the waste has been completed.

Figure 4.22: PacPyro 300 kg/h Pyrolysis Pilot Plant



### 4.2.8 Renewable Oil Corporation P/L process

Renewable Oil Corporation (ROC) is the exclusive licensee of the Canadian Dynamotive flash pyrolysis process. ROC has indicated that this technology is not suitable for processing heterogeneous wastes such as those generated by abattoirs. Their emphasis is based on the processing of clean wood chips for power generation.

### 4.2.9 ZWT GmbH process

While ZWT is not an Australian company, this process is also reviewed because it is a well proven pyrolysis process that is specifically designed for waste materials, including municipal and industrial sludge. ZWT Wasser und Abwasser Technik is a small to medium enterprise operating predominately in Germany. It has offices in Bayreuth, Kronach and Schleitz and manufacturing facilities in Eisleben. It supplies wastewater treatment plants and biomass conversion facilities to small communities predominately in Germany and Austria. It has a staff of 300 people and an annual turnover of €42 million. As indicated in Section 4.1.5, ZWT has improved and simplified the pyrolysis technology originally developed by the former Australian company ESI in Perth. The technology and details of the commercial 6 tpd plant processing sewage sludge has already been described in Section 4.1.5 of this report. ZWT also has a 40 kg/h (1 tpd) pilot plant which has been operational for the past 10 years processing a variety of wastes in both oil condensing and syngas combustion modes. This facility is located at their workshop/manufacturing site in Eisleben. A picture of the pilot plant, showing the reactor at the bottom and the syngas combustor on the top is depicted in Figure 4.23.

**Figure 4.23: ZWT Pyrolysis Pilot Plant**



## Waste to energy: Alternative uses for paunch waste and DAF sludge

Typical process performance data when pyrolysing various waste streams are shown in Table 4.2.

**Table 4.2: ZWT Pyrolysis Results for Various Wastes**

Feedstock	Char Yield (% dry weight)	Oil Yield (% dry weight)
<b>Sewage Sludge</b>	50-75	5-12
<b>Tannery Sludge</b>	50-75	5-14
<b>Tannery Shavings</b>	50-60	10-15
<b>Meat and Bone Meal</b>	40-50	20-26
<b>Pork Rind</b>	40-50	15-20
<b>Coffee Bean Residues</b>	30-40	NA
<b>Canola Seed Cake</b>	38	26.5
<b>Oily Sludge</b>	40-60	15-30

ZWT indicate that they prefer to process waste material with a TS above 90% since this minimises energy demand and produces a better quality syngas. They will however design systems to process wastes with a TS as low as 80%.

A typical mass and energy balance for the commercial Mintraching facility processing sewage sludge with a low volatile solids and energy content (only 58% and 10.3 GJ/dry t) is shown in Figure 4.24. As can be seen when processing this sewage sludge a char yield of 57% is achieved and waste heat from the combustor is available to dry the incoming sludge. Monitoring of the combustor emissions from the Mintraching facility, without any gas cleaning equipment, reveal they meet the stringent European Waste Incineration Directive<sup>17</sup> (WID) limits with the exception of particulates and SO<sub>x</sub>. Particulate emissions were 40 mg/Nm<sup>3</sup> (versus WID limit of 10mg/Nm<sup>3</sup>) and SO<sub>x</sub> emissions were 200 mg/Nm<sup>3</sup> (versus WID limit of 50 mg/Nm<sup>3</sup>). This implies only limited gas cleaning would likely be required for the processing of abattoir solid wastes.

Based on ZWTs experience when processing canola seed cake, which has characteristics very similar to a combined paunch waste and DAF sludge, they have estimated the pyrolysis performance when processing 20 dry tpd of waste. This is shown in Figure 4.25. This mass and energy balance is based on the assumption that the waste has a VS of 89% and an energy content of 21.7 GJ/dry tonne. As can be seen, ZWT estimate that such a facility will produce 8 tpd of char (a yield of 40% on a dry weight basis) and generate 7.18 GJ/h of energy to dry the incoming sludge. This is sufficient energy to dry the sludge from a TS of 25% to over 90%, making the integrated facility independent of fossil fuels. ZWT estimate that the capital cost of such a facility, excluding the dryer would be €2.14 million, which equates to \$3 million at current exchange rates.

ZWT is capable of conducting pilot plant pyrolysis trials on abattoir wastes and have indicated that 500 kg of dried material would be required for such trials. The cost for one set of trials has been estimated at €6000 (\$8,600) by ZWT. This is exclusive of drying the feedstock and transporting it to Germany.

<sup>17</sup> Directive 2000/76/EC of the European Parliament and Council on the incineration of waste, December 4, 2000.



Figure 4.24: Mass and Energy Balance for Commercial Sludge Pyrolysis Plant

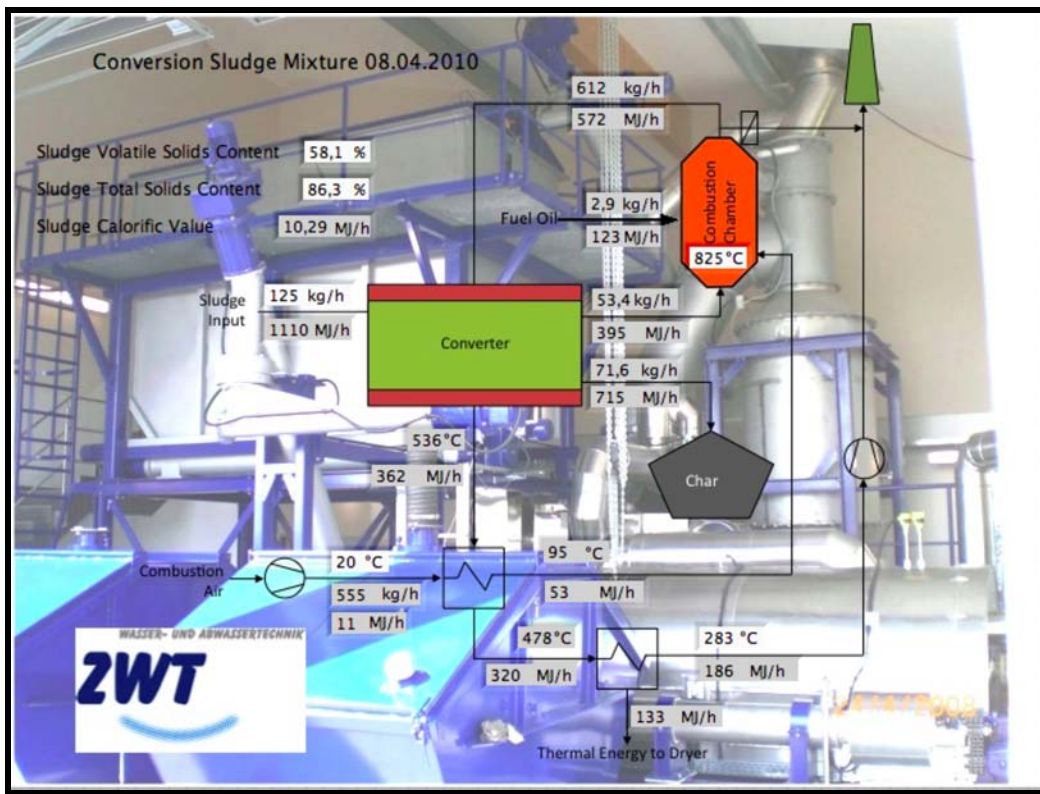
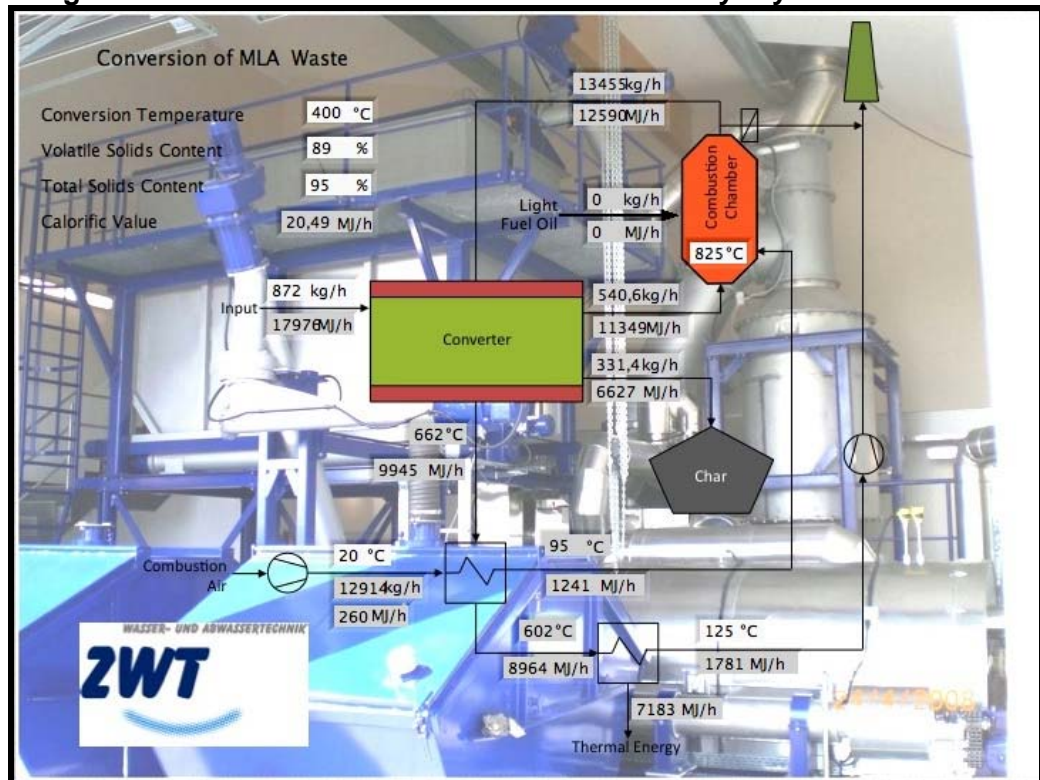

Figure 4.25: ZWT Estimation of Abattoir Waste Pyrolysis Performance



### 4.3 Site visit to Black is Green P/L in Mackay

A site visit was made to BiG on 17th August 2010. Trevor Bridle was accompanied by Tim Byrne of MLA and Mr Simon Stahl of Nippon Meat Packers on this site visit. The workshop facilities of BiG in Mackay as well as a nearby field site were visited. Dr James Joyce of BiG was the host for the visit. The BiG 2200 Unit was in the workshop for routine maintenance during the visit and hence a thorough examination of the unit was possible. A picture of the unit in the workshop is shown in Figure 4.26. The fundamentals of the BiGchar gasifier has already been covered in Section 4.2.3 of this report and will thus not be repeated here. The 2200 Unit has five operational hearths and a char out-loading hearth at the bottom of the unit. The unit is constructed of 304 stainless steel and has an insulated plenum around its circumference which is clad in galvanised iron. This minimises radiation losses from the gasifier. The gasifier has a nominal capacity of 1 tph of dry feed-stock. Solid retention time in the gasifier is typically less than 30 minutes and novel system is used to control retention time as a function of particle size. Solids temperature reaches about 400 °C on the last hearth and gas temperatures reach a maximum of about 600 °C. Thermocouples on the hearths are used to set the dampers which control airflow and hence combustion in the unit.

BiG has experience in processing sugar cane trash, green waste, sawdust and woodchips. Dr Joyce indicated that very little information is available on the quality of the exhaust from the unit but indicated that at minimum a venturi scrubber would be required to reduce particulates to acceptable levels. BiG has no information on the emission standards that regulatory authorities would apply to commercial waste gasifier's in Queensland. It is however likely that at minimum, standards would be set for particulates, CO, NO<sub>x</sub> and SO<sub>x</sub>.

**Figure 4.26: BiGchar 2200 Unit**



A visit was also made to a site near Mackay where the BiG 1000 unit was being used to generate char for field trials. This unit was processing wood chips. Photographs of the unit, the feed material and the char are shown in Figures 4.27 to 4.29. The 1100 unit is not double-shelled and as a result there was significant radiation heat loss from the gasifier. It was very hot when standing close to the unit. In addition the vents on each hearth were closed as there are sufficient “leaks” in the single-shelled system to provide the air necessary for gasification. There was not a continuous feed to the gasifier. The operator routinely fed a bucket-full of woodchips onto the inclined conveyor shown in Figure 4.28. The woodchips appeared to have a maximum size of about 60 mm in length. Each time the woodchips were fed onto the conveyor there was a “puff” of smoke and particulates emitted from the stack due to momentary imbalances in fuel/air ratios. The char discharged from the bottom of the gasifier was routinely wetted with a fine spray of water to prevent spontaneous combustion. The char particle size appeared to range from dust to up to 20 mm in size, indicating that on charring, the woodchips are comminuted by shear action within the gasifier.

**Figure 4.27: BiGchar  
1000 Unit**



**Figure 4.28: Feedstock**



**Figure 4.29: Char**

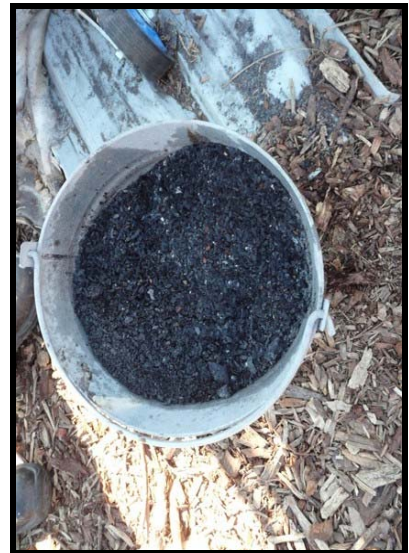

#### 4.4 Budget pyrolysis economics

Based on the information provided by the pyrolysis vendors and the “in-house” information held by Bridle Consulting it is possible to generate order-of-magnitude economics for the pyrolysis of paunch waste and DAF sludge. The major uncertainties in development of these economics include:

- uncertainties regarding the waste characteristics,
- uncertainties regarding the economic impact of drying the feed stock,
- uncertainties regarding the performance of the pyrolysis process on these wastes.
- uncertainties regarding the value of the char produced, and,
- uncertainties regarding economic credits from char carbon sequestration.

### 4.4.1 Waste characteristics

There is very little data on the characteristics of paunch waste and DAF sludge. The only relevant data for pyrolysis was found in a 2002 MLA report on contaminants in solid wastes<sup>18</sup> and a 2005 report on fossil fuel reduction<sup>19</sup>. The 2002 study analysed 4 samples of paunch waste and one DAF sludge sample for TS, VS, heavy metals and organochlorine pesticides and PCBs. The 2005 study reported one sample of each paunch waste and DAF sludge was analysed for a variety of relevant parameters in April 2001. This data is shown in Table 4.3.

**Table 4.3: Paunch waste and DAF sludge Characteristics**

Parameter	Units	Paunch Waste	DAF Sludge	Combined Value
<b>TS</b>	%	24.5	24.9	24.7
<b>VS</b>	% of TS	86.5	96.8	89
<b>Ash</b>	% of TS	13.5	3.2	11
<b>Lipids</b>	% of TS	5.7	61.8	19.8
<b>Proteins</b>	% of TS	8.1	7.2	7.9
<b>Carbohydrates</b>	% of TS	72.9	27.5	61.6
<b>Total Nitrogen</b>	% of TS	1.29	1.15	1.3
<b>Total Sulphur</b>	% of TS			0.2
<b>Carbon</b>	% of TS			44.7
<b>GCV</b>	GJ/dry tonne	13.02	38.09	21.7
<b>Chromium</b>	mg/kg	5.4	9.2	7
<b>Copper</b>	mg/kg	12.2	8.2	10
<b>Nickel</b>	mg/kg	2.6	3.4	3
<b>Zinc</b>	mg/kg	106	82.7	90
<b>Organochlorines</b>	mg/kg	<0.01	<0.01	<0.01

All the data in Table 4.3 is derived from the 2005 study with the exception of the TS, metal and organochlorine data, which is derived from the 2002 MLA study. The 2005 study indicated the dry weight ratio of paunch waste to DAF sludge was 3:1 and this ratio was used to calculate the Combined Value data in Table 4.3. Finally, Bridle Consulting has estimated the carbon and sulphur values for the combined waste stream. The data for the combined waste stream in Table 4.3 has been used in the development of budget economics for pyrolysis. It should be noted that these characteristics are typical of sewage sludge, with the exception that nitrogen, sulphur and heavy metal concentrations are significantly higher in sewage sludge. Another factor worthy to note is the high carbohydrate fraction in paunch waste and the high lipid (fat) fraction in DAF sludge. On this basis pyrolysis of paunch waste would produce high char yields while pyrolysis of DAF sludge would produce high syngas yields.

### 4.4.2 Drying issues

With the exception of Crucible Carbon, all of the vendors contacted indicated that the paunch waste and DAF sludge would require drying prior to pyrolysis. The minimum practical TS value is regarded to be 80% as below this value the energy demand of the pyrolyser would be too high and the quality of the syngas would be poor. While there are many different types of commercial

<sup>18</sup> MLA, "Assessment of Contaminants in Waste Solids from Meat Processing Wastewater Streams", 2002.

<sup>19</sup> MLA, "Reduction in Fossil Fuel-Derived Energy Demand in 5 years at Dinmore Food", Project PIP.104A, August 2005.

dryers on the market for this economic assessment only solar dryers and belt dryers are considered. This is due to their simplicity and the use of free (solar) or low grade waste energy sources. Belt dryers can use any waste energy source as long as the temperature is above about 45 °C and there are probably many such waste energy sources at most abattoirs.

### 4.4.3 Pyrolysis performance

There is currently no pyrolysis performance data on paunch waste and DAF sludge. Of the vendors contacted only BiGchar and ZWT have estimated process performance when processing these waste streams. As a result the data from these vendors has been used to develop mass and energy balances and budget economics for pyrolysis of this combined waste stream. It should be noted that the BiGchar process is gasification rather than pyrolysis. The char yield and syngas energy available for reuse for these processes is summarised in Table 4.4.

**Table 4.4: Pyrolysis/Gasification Performance Data for Economic Analysis**

Process	Char Yield (% dry weight)	Syngas Energy Available (GJ/t dry feed)
<b>Gasification</b>	26.7	8.9
<b>Pyrolysis</b>	40	8.6

It should be noted that the BiGchar gasification syngas energy available has been modified to reflect the fact that BiGchar assumed the feedstock GCV was only 12 GJ/t whereas the value used in this report is 21.7GJ/t, as shown in Table 4.3. The data in Table 4.4 reflects the fact that char yield in gasification is much lower than that for pyrolysis due to combustion of some of the feedstock.

### 4.4.4 Char value

The commercial value of biochar is yet to be defined by the agricultural industry but it is estimated that the value will probably range from \$200 to 600 per tonne. For the purposes of this economic analysis a value of \$300/tonne is used. Currently the potential for obtaining credits for carbon sequestration when char is used in agriculture is also unclear, although scientifically it has been proven beyond any doubt that carbon in char is sequestered for geological time when land-applied. For the purposes of this study it is assumed that a credit of \$20/tonne of carbon will apply. An alternate use of the char is to replace some of the coal burnt in the abattoir boilers. For this use a value of \$100/tonne is applied.

### 4.4.5 Budget economics

Budget economics have been developed for plants processing 5 and 20 dry tpd of combined paunch waste and DAF sludge. This covers the expected range of the mass of this solid waste from medium to large abattoirs (800 to 3000 head of cattle per day). The capital costs are based on those provided by BiGchar for their gasifier and ZWT for their pyrolyser. It is assumed that solar dryers are used for gasification plants and belt dryers for pyrolysis plants. This then provides a low cost capital estimate for gasification and a high cost estimate for pyrolysis. Costs for solar and belt dryers were obtained from existing data held by Bridle Consulting. In developing annualised operating and maintenance costs for the facilities the following assumptions have been made:

- fifty percent of the plant capital cost is loan funds and the interest rate is 6%.
- maintenance costs are 3% of the total capital cost.

## Waste to energy: Alternative uses for paunch waste and DAF sludge

- the operational labour for the plant is 3 persons for the 20 tpd facilities and 2 persons for the 5 tpd facilities, at \$60,000 per person/annum.
- power cost is \$100/MWh. Power sales are credited at \$120/MWh, which includes a REC component.
- revenue from char sales to agriculture and carbon credit is \$300 and \$20 per tonne respectively. An alternate is use of the char to replace coal in the abattoir boilers. For this option the char value is assumed to be \$100/tonne.

Simplified Mass and Energy balances for gasification and pyrolysis of 20 dry tpd of waste are shown in Figures 4.30 and 4.31. For this analysis solar drying has been selected for gasification plants and belt dryers for pyrolysis plants. This favours the gasification option as no process heat is required for waste drying. This was done to show the maximum power that could be generated from the gasification option, using gas engines with an efficiency of 38%.

**Figure 4.30: M&E Balance for Waste Gasification (20 dry tpd)**

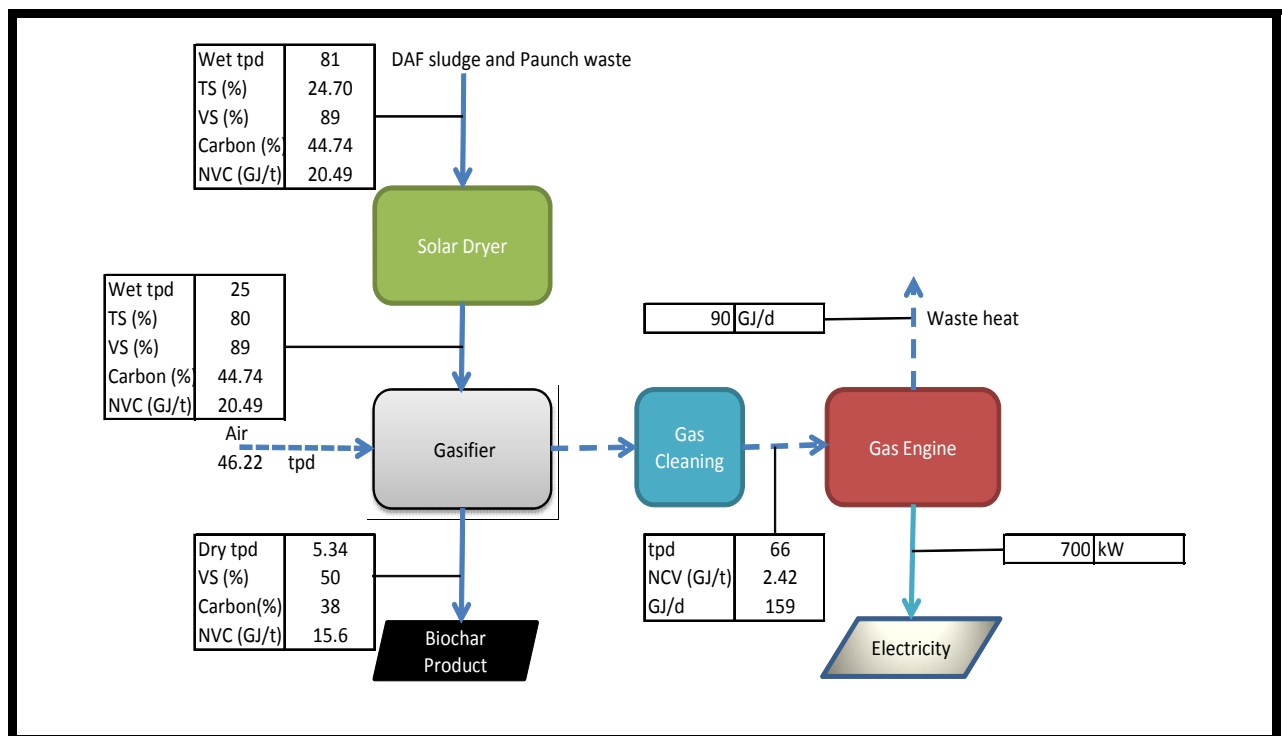

As can be seen the 20 dry tpd gasification facility is estimated to produce 700 kW of power and 5.34 dry tpd of char. It would also be possible to enhance the solar dryer by using the waste heat from the gas engine. The cost of the gasification system including gas cleaning and the gas engine is estimated at \$1.51 million, based on the information provided by BiG. It must however be emphasised that based on data reported in the literature extensive gas clean-up is required to produce a gas suitable for long-term use in gas engines. Thus the costs provided by BiG for gas clean-up may be an under-estimate of what is required. Bridle Consulting has estimated the solar dryer capital cost at \$4.5 million, bringing the total capital cost to \$6.01 million. The power draw for the entire system is estimated at 120 kW.

## Waste to energy: Alternative uses for paunch waste and DAF sludge

The 20 dry tpd pyrolysis facility is estimated to produce 8 dry tpd of char and sufficient energy in the syngas to heat the pyrolyser and provide the process heat for drying of the waste in a belt dryer. Based on information provided by ZWT the capital cost of the pyrolysis system, including the syngas combustor and necessary heat exchangers is estimated at \$3 million. Based on the data from ZWT it is assumed that no gas cleaning equipment is required. Bridle Consulting has estimated the capital cost of the belt dryer to be \$4.66 million, bringing the total capital cost of the system to \$7.66 million. The power draw for the entire system is estimated at 105 kW.

The budget economics for both gasification and pyrolysis of the combined waste stream is summarised in Tables 4.5 and 4.6. For the small 5 tpd facilities it is assumed that they will operate 5 days per week (as per smaller abattoirs) while the larger 20 tpd facilities are assumed to operate 7 days per week. That is, for smaller plants they process 25 tonnes per week while the larger plants process 140 tonnes per week of dry solid waste.

**Figure 4.31: M&E Balance for Waste Pyrolysis (20 dry tpd)**

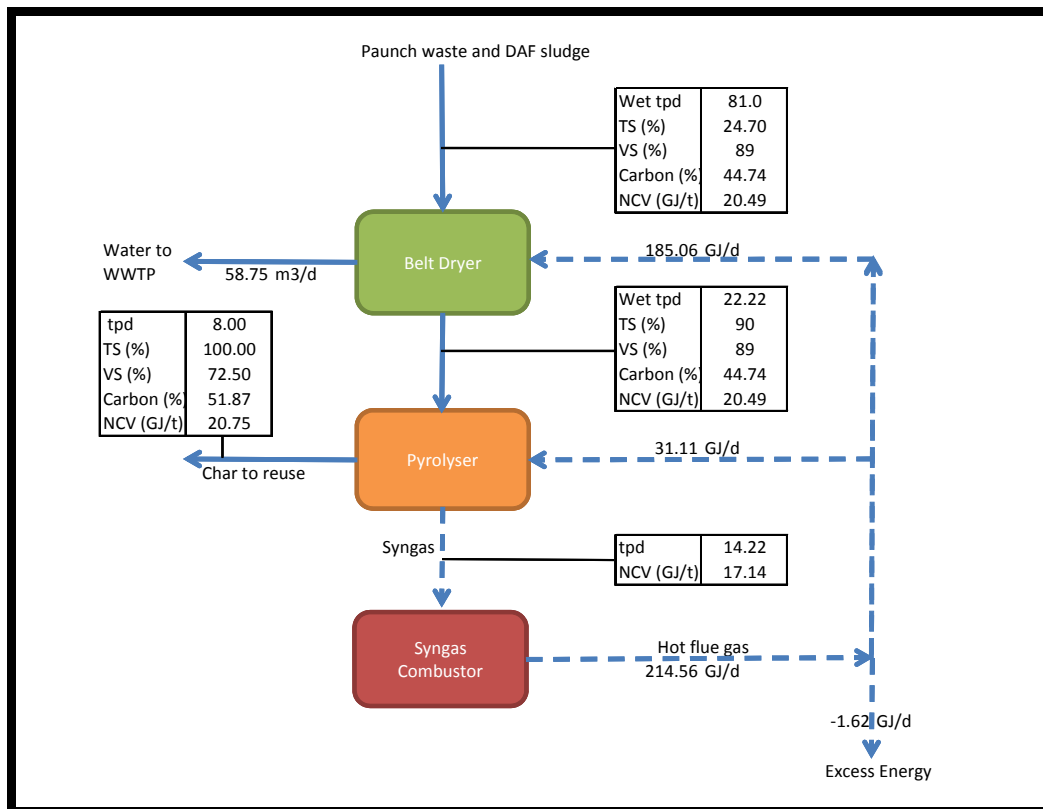

The data in Tables 4.5 and 4.6 clearly indicate the benefits of power generation and use of the char in agriculture with a high commercial value. The data indicates that for small plants of 5 dry tpd throughput the economics are at best marginal. The only option that looks potentially profitable is gasification with power generation and char to agriculture. All the other options incur costs ranging from \$53 to \$212 per dry tonne of feedstock. As is to be expected, the economics for larger 20 tpd facilities look far more attractive. Depending on the process used and the char end-use, credits of between \$24 and \$94 per dry tonne are possible. Only pyrolysis without power generation and char use as a fuel does not provide a positive return.

## Waste to energy: Alternative uses for paunch waste and DAF sludge

Whilst these economics are very preliminary in nature they do indicate that gasification or pyrolysis of paunch waste and DAF sludge, with power generation, can provide positive returns for larger plants.

**Table 4.5: Budget Economics for Waste Gasification and Pyrolysis: Char to Agriculture (\$/annum)**

Cost Item	5 tpd gasifier	5 tpd pyrolyser	20 tpd gasifier	20 tpd pyrolyser
<b>Annual Costs</b>				
-Capital Repayment	42,957	91,608	180,287	229,800
-Maintenance	42,957	91,608	180,287	229,800
-Manpower	120,000	120,000	180,000	180,000
-Electricity	28,080	24,960	105,120	91,980
<b>Total Annual Cost</b>	<b>233,994</b>	<b>328,176</b>	<b>645,694</b>	<b>731,580</b>
<b>Annual Revenues</b>				
-Char sales	104,130	156,000	584,730	876,000
-Carbon credits	2,638	5,394	14,813	30,289
-Electricity sales	130,974	0	735,467	0
<b>Total Annual Credit</b>	<b>237,742</b>	<b>161,394</b>	<b>1,335,011</b>	<b>906,289</b>
<b>Net Credit</b>	<b>3,748</b>	<b>-166,782</b>	<b>689,317</b>	<b>174,709</b>
<b>Net Credit (\$/dry t)</b>	<b>2.88</b>	<b>-128.29</b>	<b>94.42</b>	<b>23.93</b>

**Table 4.6: Budget Economics for Waste Gasification and Pyrolysis: Char to Boiler (\$/annum)**

Cost Item	5 tpd gasifier	5 tpd pyrolyser	20 tpd gasifier	20 tpd pyrolyser
<b>Annual Costs</b>				
-Capital Repayment	42,957	91,608	180,287	229,800
-Maintenance	42,957	91,608	180,287	229,800
-Manpower	120,000	120,000	180,000	180,000
-Electricity	28,080	24,960	105,120	91,980
<b>Total Annual Cost</b>	<b>233,994</b>	<b>328,176</b>	<b>645,694</b>	<b>731,580</b>
<b>Annual Revenues</b>				
-Char sales	34,710	52,000	194,910	292,000
-Carbon credits	0	0	0	0
-Electricity sales	130,974	0	735,467	0
<b>Total Annual Credit</b>	<b>165,684</b>	<b>52,000</b>	<b>930,377</b>	<b>292,000</b>
<b>Net Credit</b>	<b>-68,310</b>	<b>-276,176</b>	<b>284,683</b>	<b>-439,580</b>
<b>Net Credit (\$/dry t)</b>	<b>-52.55</b>	<b>-212.44</b>	<b>40.00</b>	<b>-60.22</b>

### 4.5 Recommended pyrolysis test programme

Based on this review it is recommended that pilot or laboratory scale testing of gasification and pyrolysis of paunch waste and DAF sludge be undertaken. Furthermore a detailed characterisation of these two abattoir waste streams is recommended. Rather than the original



plan to test 5 pyrolysis processes it is recommended that one gasification and one pyrolysis process be tested. Based on the information provided by the Australian pyrolysis/gasifier vendors to this review it is suggested that the BiGchar gasification process and the Pacific Pyrolysis process be evaluated at pilot plant or laboratory scale. This will allow a reasonable amount of process and cost information to be generated on these two processes from the funds that are available for this task. Ideally a combined stream of paunch waste and DAF sludge would be trialled since paunch waste has a low calorific value and hence the economics of processing paunch waste alone will not likely be attractive. It is recommended that discussion with BiG and Pacific Pyrolysis be entered into to develop suitable testing programmes. At minimum the trials must be designed to develop sound elemental, contaminant and mass and energy balances for the gasification and pyrolysis processes that will then allow the economics of these processes to be developed in more detail. It is likely that up to five tonnes of dried feedstock will be required for these trials, depending on the scale of the equipment to be used by the vendors. Industry will need to source a means of drying this quantity of paunch waste and DAF sludge.

It is recommended that a waste characterisation programme is embarked on. At least five samples of paunch waste and DAF sludge needs to be analysed for the parameters identified in Table 4.3 of this report.

## 5 Success in achieving objectives

This review of waste pyrolysis has confirmed that the technology is used at commercial scale predominately in Europe and Japan but that there are no commercial facilities operating on abattoir solid wastes. Eight Australian pyrolysis vendors were identified but none have any experience with the processing of abattoir solid wastes. Preliminary economic analysis reveals that pyrolysis of abattoir wastes could be commercially attractive and that this process could reduce the carbon footprint of abattoirs. All the objectives of this study have been successfully achieved.

## 6 Impact on meat and livestock industry – Now and in five years time

If pilot plant testing of abattoir solid wastes confirms that pyrolysis/gasification is economically viable then this technology could have a profound impact on the environmental sustainability of the meat processing industry in 5 to 10 years. Reductions in waste processing costs and reductions in the carbon footprint of abattoirs would result from the adoption of this technology.

## 7 Conclusions and recommendations

### 7.1 Conclusions

Based on the findings of this study the following conclusions are drawn:

1. There are numerous successful commercial waste pyrolysis facilities operating worldwide, predominately in Europe and Japan. Most of these facilities process MSW and industrial wastes. There are no commercial facilities processing abattoir solid wastes.
2. There is a healthy emerging waste pyrolysis business sector in Australia. Eight companies were identified that are marketing and developing waste pyrolysis and

gasification technologies. None of these companies have any experience in the processing of abattoir solid waste streams such as paunch waste and DAF sludge.

3. A preliminary economic assessment of pyrolysis and gasification technologies for the processing of dried paunch waste and DAF sludge revealed that under certain conditions the process can be economically viable. Whilst these economics are very preliminary in nature they do indicate that gasification or pyrolysis of paunch waste and DAF sludge, with power generation, can provide positive returns for larger scale plants.

### **7.2 Recommendations**

Based on the outcomes of this study the following recommendations are made:

1. It is recommended that a project on detailed paunch waste and DAF sludge characterisation is conducted to provide the information necessary to assess the potential of pyrolysis and gasification for the cost-effective processing of these waste streams.
2. To confirm the budget economics developed in this study it is recommended that pilot plant trialling of Australian pyrolysis and gasification technologies are undertaken.