



FEEDLOT DESIGN AND CONSTRUCTION

20. Water trough design and sewer systems

AUTHORS: Rod Davis and Peter Watts

Introduction

Water troughs should allow cattle access to an adequate supply of good quality water for their survival, welfare and performance without causing negative environmental impacts for the feedlot.

Design objectives

The water trough system should

- provide a fresh, cool, clean, palatable and adequate volume of water to livestock
- provide sufficient access area to enable all cattle to drink regularly
- be strong, durable and resistant to damage from cattle and pen-cleaning equipment
- allow for easy and regular cleaning inside the trough
- allow for easy cleaning of the trough exterior with minimal obstruction during pen cleaning
- not allow manure to accumulate underneath or be a breeding area for flies or vermin
- allow for easy maintenance of pipe and drainage fittings
- not cause wet areas or drainage problems in pens or lead to pen maintenance issues.

Mandatory requirements

Compliance with

- Australian Animal Standards and Guidelines for Cattle (DAFF, 2013)
- National Guidelines for Beef Cattle Feedlots in Australia (MLA, 2012a)
- National Beef Cattle Feedlot Environmental Code of Practice (MLA, 2012b)
- NFAS standards (AUS-MEAT, 2014).

Technical requirements

The most suitable layout and dimensions of water troughs will be based on the volume of water per unit access length, the depth of trough, trough height, drainage point and position, side enclosure, float valve protection and on preventing cattle entering the troughs.

Capacity

The water delivery system and water trough volume must be adequate to meet the daily water requirements and peak demand of the cattle. Further information on cattle drinking water is provided in *Section 4 – Water requirements*.

The volume of water per unit access length must consider

- maximum flow rate of the reticulation system
- temperature of water in the trough
- volume of water flushed into the pens during cleaning.

The volume of water wasted into the pen with each flushing is minimised by using low-volume troughs; long, narrow, shallow troughs are preferable to large, deep, high-volume circular troughs.

Shape

Most feedlot troughs are rectangular rather than round as these fit along fence lines, are more easily cleaned internally and easier to clean around with machinery; they provide more linear space than an equivalent capacity round trough.

The internal cross section of trough is generally either a u-shaped or trapezoid (wider at the top than bottom) with varying degree of side angle.

Length

A minimum of 25 mm/head of linear trough space available should be provided during normal weather conditions and 75 mm/head during hot conditions (MLA, 2006). Available length is the trough length less the length unavailable due to float protection.

Materials

All materials should have a life expectancy of ten years or more. Common construction materials are reinforced concrete, polyethylene, fibreglass and steel.

Concrete is the most common material because it is more durable and can stabilise water temperature. Troughs can be cast on site but most are prefabricated units.

All designs should meet the industry standards for the material being used. Polyethylene or fibreglass water troughs should be made of ultraviolet resistant materials or have a durable coating to protect against deterioration under sunlight.

Surface coating

Over time, the inside surface of a concrete trough becomes difficult to clean as it deteriorates through hardness of the water, action of cattle licking, cattle saliva, enzymes in feed stuffs and mechanical cleaning. The surface can be protected by a fibreglass or polyethylene insert or by coating the surface with an epoxy resin – best applied when the trough is new.

See *Section 19 - Feeding systems* for further information on the use of coatings to protect the surface of concrete against corrosion and wear.

Trough support structure

Troughs should be enclosed underneath with vertical external sides that extend from the top of the trough to the concrete apron. This provides the trough and piping with some protection from machinery and cattle, and allows cleaning of the apron right up to the trough base.

Fibreglass or polyethylene troughs should be protected by full concrete sides rather than open steel frames.



Rectangular water troughs fit well along fence lines.



Fibreglass insert in a trough (Position D).



Poor design of trough support allows manure to build up, creating odour and encouraging flies to breed.



Unprotected floats can be damaged resulting in an overflowing trough and wet spots within the pens.



Steel cage to protect float



Concrete float cover and a trough cleaning device shaped to exactly fit the trough's internal shape.

Open-framed bases do not fully protect the trough and also allow manure to accumulate under the trough. This enhances fly breeding, promotes odour and makes cleaning more difficult.

Cattle access

Cattle must be prevented from stepping or falling into water troughs by sides extended high enough from the ground and an exclusion bar over the surface of the trough.

Steel or timber frames are constructed over the trough to prevent cattle entry while in-fence troughs can be protected by the fence panels themselves. Fence panels either side of the trough should be reinforced while stand-alone troughs must be protected by a separate structure.

The flow control system and supply and drainage pipework should be protected from damage by cattle and machinery, as when it is located in the void under the trough and contained within an enclosed trough base.

Cattle play with and damage unprotected valves. Besides any costly repairs, the trough will overflow, causing excessive bogging, pen floor damage and odour generation.

Float protection must be sturdy with either an open frame (e.g. weldmesh) or preferably fully enclosed and made from galvanised sheet steel, fibreglass or concrete. Protection covers must be easily removable to allow maintenance access to float valves and gate valves. Float covers reduce available drinking access along the length of the trough.

Aprons

The area surrounding the water trough is a high traffic area. An apron will allow access to the trough under all weather conditions, prevent the ground becoming muddy or holes developing and allow cleaning of manure around the trough.

Concrete aprons should be at least 3 m wide all around the trough. Figures 1 and 2 illustrate typical construction details of a trough located along the pen-dividing fence. A width of 3 m allows full access and supports the full width (2.4 m) of pen-cleaning machinery (e.g. bobcat, loader). Aprons should have thickened edges and reinforcement to support the weight of pen cleaning machinery.

Water troughs need to be level when installed. However as all pens have some slope, there would be 150 mm fall over a 5 m long trough in a 3% pen. Hence, the grade of the apron must vary around the trough. The apron on the upslope side of the trough may be kept level or slope (e.g. 1%) down from the trough.

Figures 1, 2 and 3 illustrate the resulting grades of an apron with a level upslope and located on a pen with a down slope of 3% and cross slope of 0.5%. Figures 5, 6 and 7 illustrate the resulting grades of an apron with a 1% grade way from the trough on the upslope side and located on a pen with a down slope of 3% and cross slope of 0.5%. The greater the pen slope, the greater the difference between the level apron pad and the pen surface. Grading down the apron to tie in with the finished pen surface minimises fill.

During pen construction, the apron is normally cut in to the finished surface (compacted clay or gravel) so that the top of the concrete apron is 30–50mm above the finished surface (Figure 2). This allows for the impermeable manure pen substrate to be 30–50mm in thickness, and therefore level with the finished concrete apron surface. The area cut out between the edge of the apron and finished surface is backfilled with pen surface material.

An alternative is to cast the apron on top of the finished pen surface but this increases the amount of fill required for the pad.

A pad will need to be formed on the finished surface to form a level base for the water trough; this is best built up with crusher dust or similar material and compacted to ensure no settlement.

Figure 3 and Figure 7 show a plan view of the water trough installed on a pen with a slope of 3% and a cross-slope of 0.5%. The grades of the apron will vary along the length of the trough as the apron is graded down to the pen surface, depending on the grade of the apron on the upslope side.

Concrete water trough aprons that are oval in shape reduce ongoing maintenance around water troughs as they eliminate wear points around apron edges, and allow cleaning equipment and machinery to operate around water troughs without catching sharp edges or 'squared' concrete lips. The equipment can operate in a circular motion around the surface of the apron (Figure 4).

Aprons should have a non-slip surface. See *Section 23 – Cattle processing* and *Section 41 – Cattle washing* for information on non-slip concrete surfaces.



Aprons allow cattle to access to the trough under all weather conditions and allow access for cleaning (Position A).

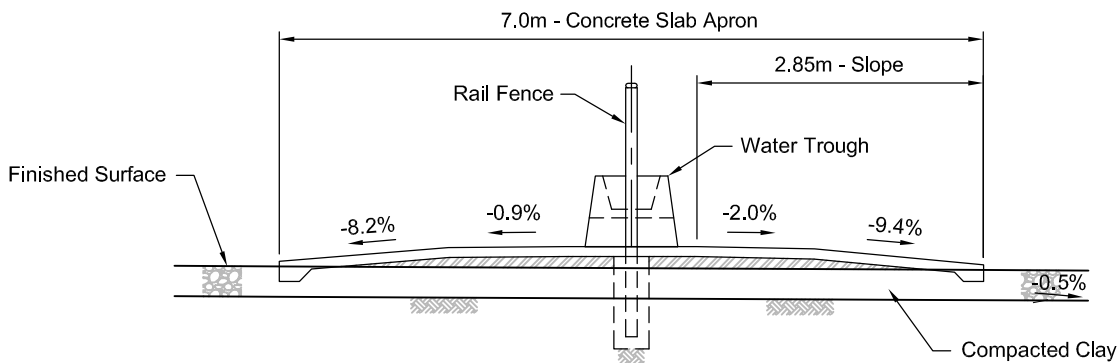

Figure 1. Typical concrete apron cross section details with 0.5% cross slope in pen.

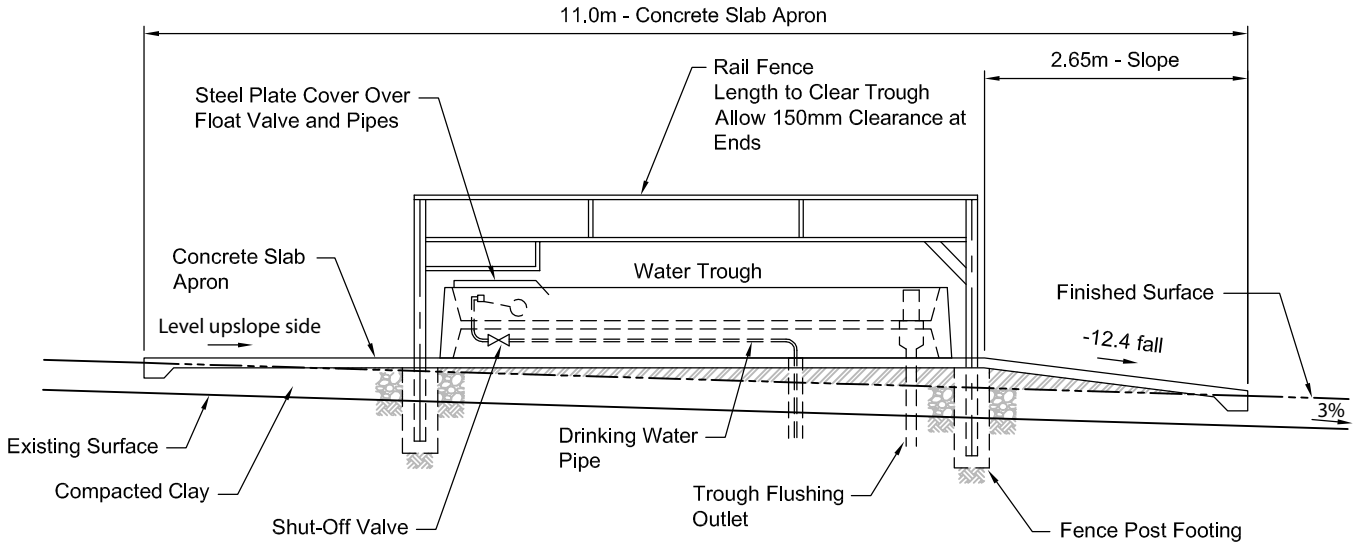
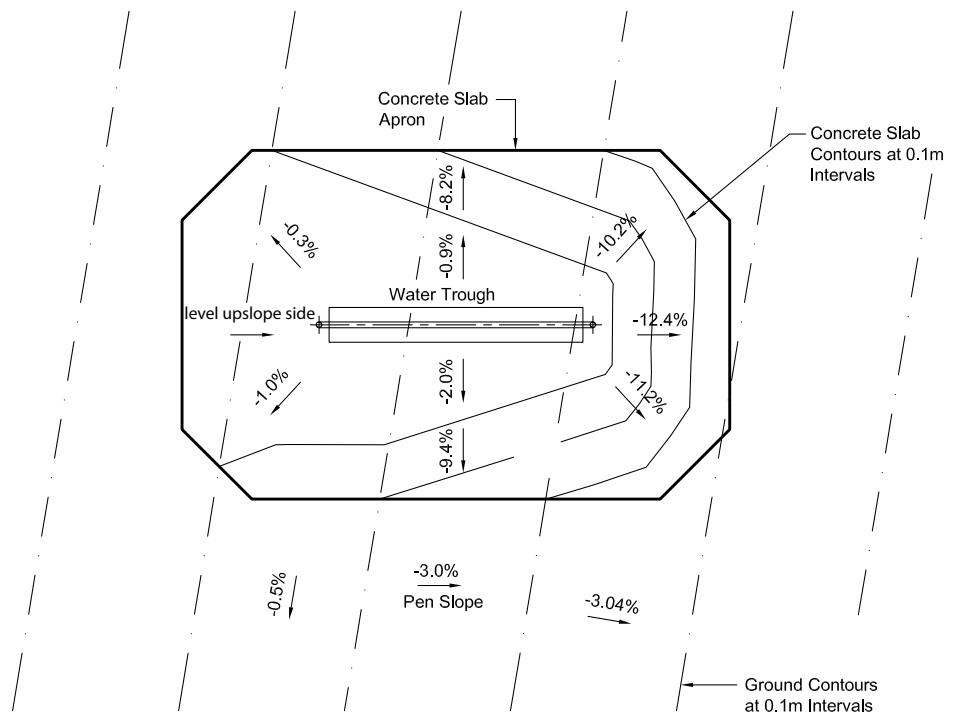
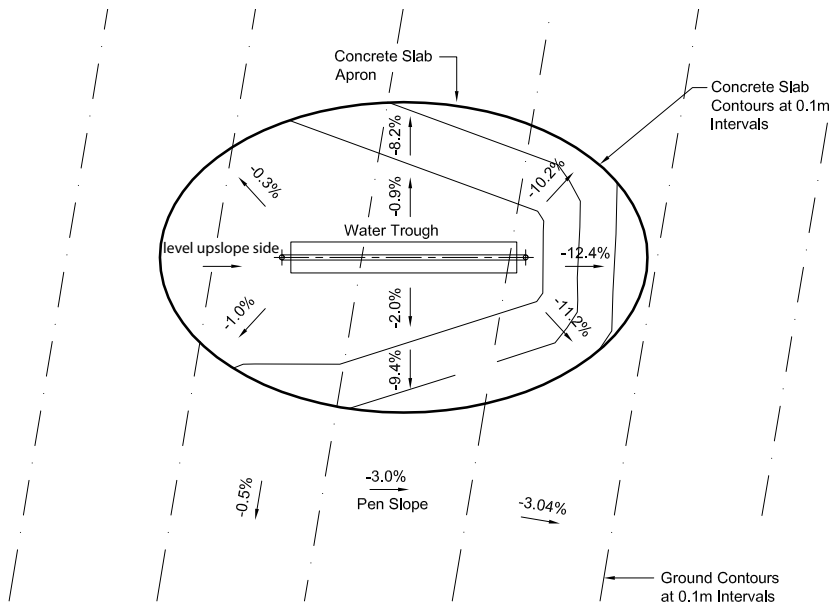

Figure 2. Typical concrete apron long-section details with 3% downslope in pen

Figure 3. Typical concrete apron plan view with level upslope side





Trapeze-shaped water trough centrally placed on an oval-shaped concrete apron.

Figure 4. Typical oval concrete apron plan view with level upslope side

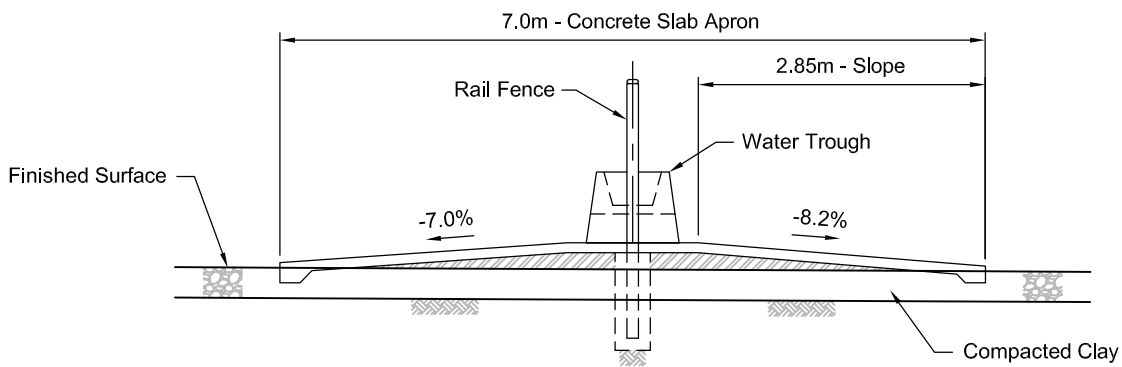

Figure 5. Typical concrete apron cross section details with apron graded down on upslope side

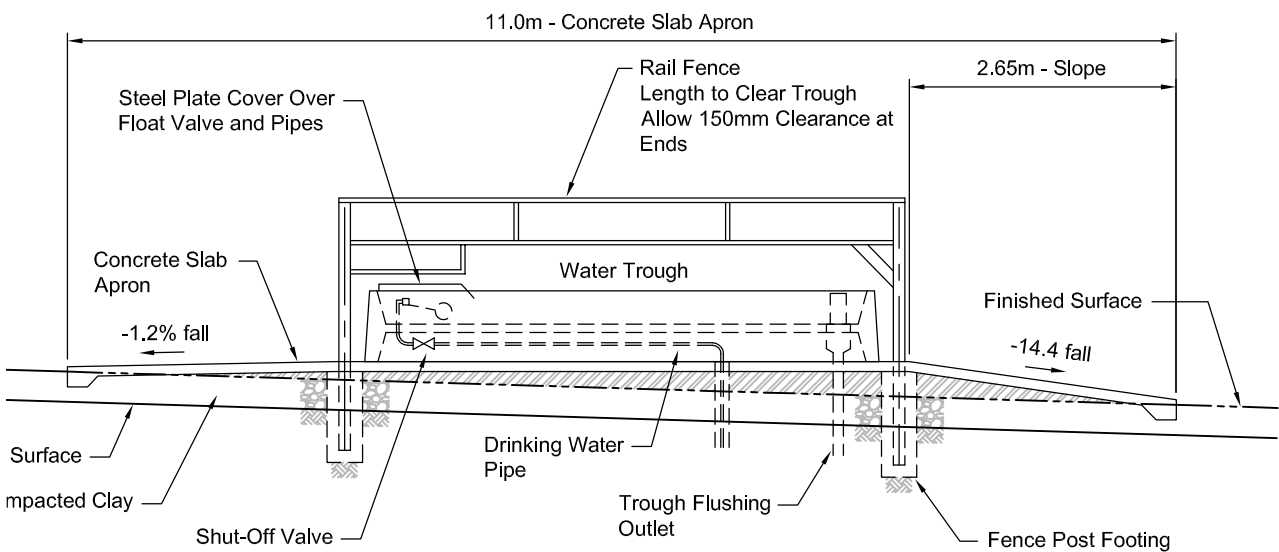

Figure 6. Typical concrete apron long-section details with apron graded down at 1% on upslope side

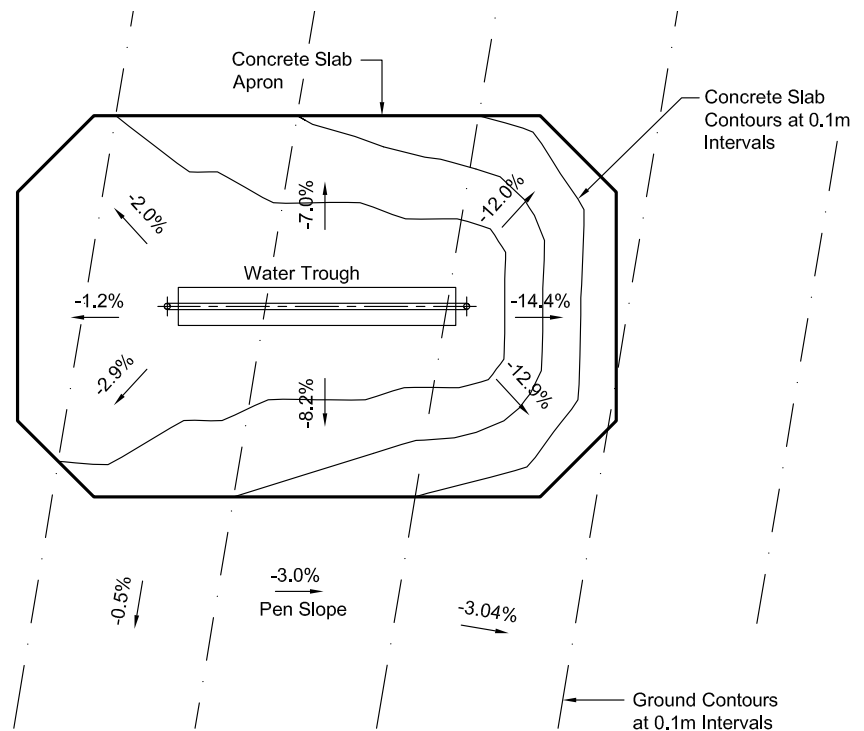

Figure 7. Typical concrete apron plan view with apron graded down at 1% on upslope side



Placing troughs between pens can help secure water supply to cattle. Note good float protection, enclosed sides and an overflow pipe. The trough can be scrubbed with a brush for cleaning.

Flow control

Troughs need some form of water level control to maintain a constant water level and minimise water loss through overflow. Sleeved or seated valves have high flow rates and a wide operating pressure range. For sleeved valves, the water level change activates a ball float to engage a piston, which opens until water level is returned to pre-determined level. For seated valves, the ball float depresses a seal against a seat.

Location in pens

Water troughs can be placed in several locations within a pen. Two locations (A and D in Figure 8) are recommended.

Water troughs (A and B) in the fence line between pens are shared between the two pens. The fence acts as a barrier to cattle entry whereas stand-alone troughs (C and D) must have a separate cattle entry barrier across the surface of the trough. Troughs in fence lines provide backup if one trough is offline due to damage (as long as individual troughs can be isolated).

Troughs in fence lines are claimed to be more readily located by new cattle as they walk the fence line. Two troughs in the fence line distribute cattle so that manure does not build up and traffic is not limited to one area.

Provision of two water troughs per pen ensures that timid cattle have good access to water, although there is a suggestion that there is increased risk of disease transmission if troughs are shared.

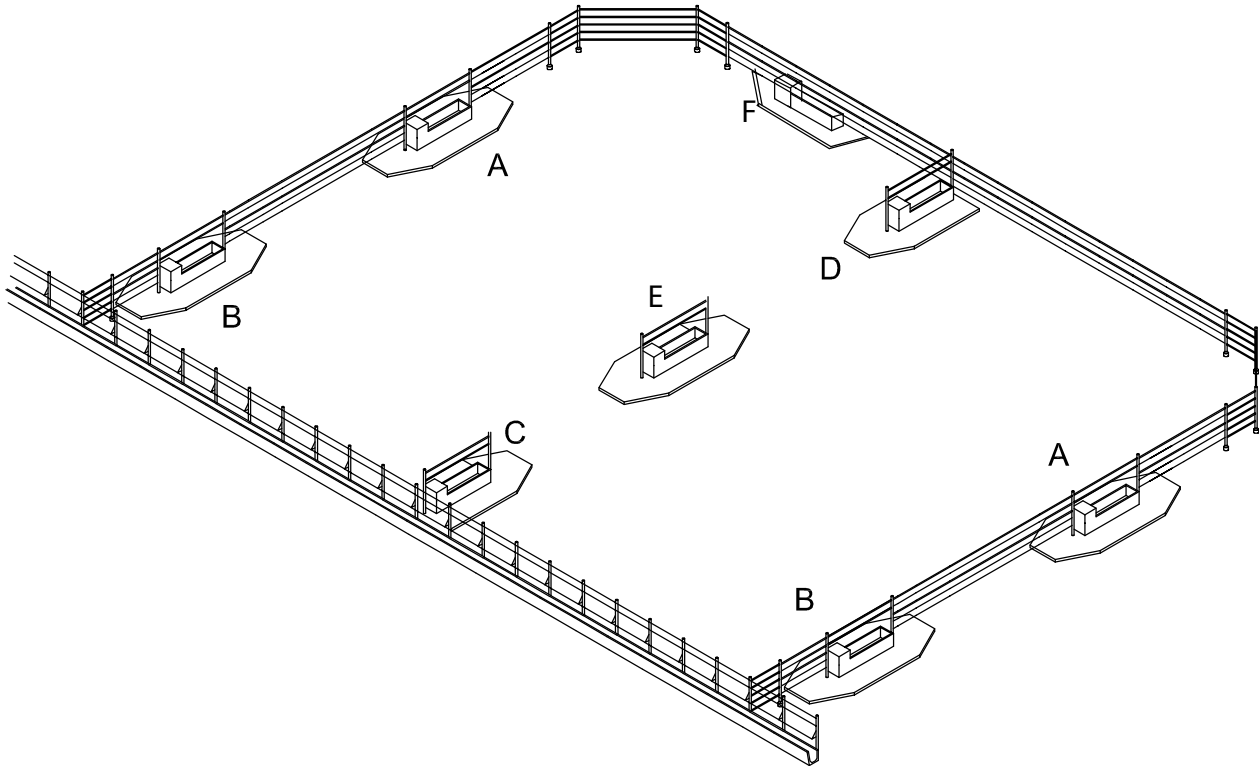

Figure 8. Options for locations of water troughs in pens

As cattle drink soon after feeding, water troughs should not be located relatively close to the feed troughs (B and C). After feeding, cattle hold grain on their muzzles and in their mouth for a time. If the troughs are too close to feed bunks, cattle will transfer more grain across to the water trough, requiring more frequent cleaning. Also water flushed from water troughs in this location during cleaning and the heavy traffic can result in rapid pen floor deterioration and multiple wear points. Troughs in this location will most likely need to be sewered.

If the trough is located on the bottom fence line near the cattle lane/drain (D), overflow, spillage and flushing water during cleaning is conveyed directly out of the pen to the drainage system and wet spots in pens are avoided. New cattle traversing the perimeter of the pen locate the water supply easily. Troughs are also likely to have less feed deposited.

Position E will require a spoon drain or sewerage line to a drainage point in lane or gully. This allows good access for machinery during pen cleaning and will allow cattle to pass easily.

Troughs should never be placed at position F because they prevent drainage from the pen.

If fence line troughs are located close to the cattle lane gates (A), releasing flushing water can cause bogholes in these high traffic areas. While stand-alone troughs located on the bottom fence line flush most conveniently into lanes, they can be difficult to clean around. Water troughs on the fence line near the cattle lane/drain can be easily accessed from the cattle lane.



A water trough placed across the bottom fence will prevent proper pen drainage – a poor design choice.



An overflow stand pipe prevents water from overflowing into the pens if a float valve breaks. The stand pipe is unscrewed for trough draining and cleaning.



Algae and dirty water in troughs can make cattle sick. Troughs must be cleaned regularly.



Leaking water troughs create wet spots in pens and should be fixed as soon as possible. A sewer system would have prevented this problem.

Covering the troughs with some form of shade or placing water troughs under the shaded areas in the pen will reduce the heat loading on the water and the trough. However, the area around the trough will stay wet longer so the concrete aprons may have to be larger. Cattle will tend to congregate under the shade and this may restrict access to the trough.

Position (C) is not recommended as it disrupts pen cleaning and makes it difficult to maintain a uniform, even pen slope.

Drainage of overflow and cleaning water

Water troughs in feedlots need to be cleaned frequently by flushing out the existing water and then adding more during scrubbing.

Each trough must be fitted with a large drainage (flushing) outlet which should be located so that drainage water flows away from the trough, preferably to a drain. A small concrete spoon drain can take water from the drainage point to the pen drain while a sewer system conveying flushing water either directly to the drain, or preferably to the retention pond, is increasingly preferred.

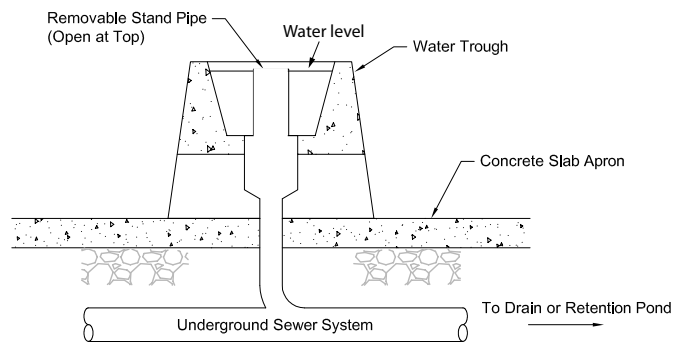

Figure 9. Stand pipe overflow and flushing system

The sewer system will also direct overflow water out of the pen if a float valve is broken or jammed (Figure 9). An alternative to this is to supply a specific overflow structure such as a recessed lip at the lower end of the trough.

Troughs are flushed simply by unscrewing the stand pipe which opens the discharge bung. Dirty water (along with grain and other debris) and flushing water is then conveyed through a network of pipes to the discharge point.

As sewer systems can become clogged by stones, grain and other debris, the underground pipe system needs good slope (>1%) and no sharp bends, while valving can provide a flushing flow. Additional flushing time is recommended to completely remove any sediment.



Trapeze-shaped water trough with galvanised float cover, and hinged neck rail to prevent cattle getting into the water trough. A boot cover on water inlet pipe prevents material from entering PVC delivery pipe. (Position E)

Quick tips

- The water delivery system and water trough capacity must be adequate to meet the daily water requirements and peak demand of the cattle.
- Rectangular troughs fit along fence lines, are easy to clean around with machinery and provide more linear space than an equivalent capacity round trough. Rectangular troughs are more easily cleaned than circular troughs.
- A minimum of 25 mm/head of available linear trough space should be provided during normal conditions
- All troughs should have vertical or near-vertical closed-in sides that extend from the top of the trough to the concrete apron. This prevents manure buildup underneath the trough where it is difficult to remove.
- Troughs should be high enough above ground level that cattle cannot step, fall or be knocked into them.
- Steel or timber frames should be constructed over the trough to prevent cattle entry.
- The flow control system and supply and drainage pipework should be suitably protected from damage by cattle and machinery but easily accessible for maintenance
- A concrete apron at least 3 m around water troughs is essential for this high traffic area and will allow cleaning of manure from around the trough. Aprons should slope a minimum of 2% away from the trough. Aprons should have a rough surface to prevent cattle slipping.
- Surface coatings are best applied to concrete water troughs before they are used.

Further reading

AUS-MEAT, 2014, NFAS Rules & Standards (April 2014), AUS-MEAT Limited, Brisbane, Qld.

Brown, L, 2006, Livestock Water System Design, Livestock Watering Factsheet, Order No. 590.304-1 January 2006, Ministry of Agriculture and Lands, British Columbia.

Blocksome, C.E. and G.M. Powell (eds). 2006. Waterers and watering systems: A handbook for livestock owners and landowners. Kansas State University Agricultural Experiment Station and Cooperative Extension Service, Manhattan, KS.

DAFF, 2013, Australian Animal Standards and Guidelines for Cattle, Department of Agriculture, Forestry and Fisheries, Australian Government, Canberra, ACT.

Kenzie, O and Williamson, K, 2000, Facilities and Environment – Feedlot Water System, Alberta Feedlot Management Guide, Agricultural and Rural Development, Alberta Agriculture.

Landefeld, M and Bettinger, J 2010, Livestock Water Development, Factsheet ANR-12-02, Ohio State University Extension, Ohio State University.

MLA, 2006, Summer feeding of feedlot cattle, Tips and Tools - Heat load in feedlot cattle. ISBN: 1 74036 505 4, Meat & Livestock Australia, North Sydney NSW.

MLA, 2011, A framework for water and energy monitoring and efficiency in feedlots, Factsheet 11: Drinking Water Usage. ISBN: 9781741915969 Meat & Livestock Australia, North Sydney NSW.

MLA, 2011, A framework for water and energy monitoring and efficiency in feedlots, Factsheet 4: Additional water measurement equipment. ISBN: 9781741915969 Meat & Livestock Australia, North Sydney NSW.

MLA, 2012a, National Guidelines for Beef Cattle Feedlots in Australia. Meat & Livestock Australia, Sydney, NSW.

MLA, 2012b National Beef Cattle Feedlot Environmental Code of Practice. Meat & Livestock Australia, Sydney, NSW.

Skinner, B, 2012, An engineer's guide to apron slabs for water points, WEDC, Loughborough University, 2012.

Taylor, K, 2010, Watering Facility Design Criteria for Cattle, Design Technical Note SD2006-1 April 1, 2010, South Dakota Technical Guide.